



Каталог колесного крепежа и аксессуаров















About Our Lug Nuts



- Constructed to enhance the luster of your wheels and provide maximum dependability and strength.
- Backed by our ISO and QS certified facilities, we manufacture each lug nut to exact fastener standards using the latest equipment available on the market.
- Cold forged for increased strength and uniformity, our lug nuts meet or exceed OEM and aftermarket application standards.
- Each lug nut is hand polished before plating, resulting in longer-lasting superior chrome finish.

Quick Reference Guide for Lug Nut Selection

						
Description	ACORN	ACORN BULGE	OPEN-END	DUPLEX ACORN	STANDARD MAG	TUNER
Application	· Steel Wheels	· Steel and Aluminum · Bulge adds increased seating surface	· Wheels with cap covering lugs	· 8 Lug Wheels · 7/8" and larger hex sizes · Also available with dome top	· Aluminum wheels that are 9/16" and 7/8" thick at stud holes	· Small diameter wheels with deep lug holes
Seat	60° taper	60° taper	60° taper	60° taper	No Taper	60° taper

						
Description	DUALIE	SPLINE	ET CONICAL	STAINLESS-STEEL CAPPED	RADIUS SEAT	ALUMINUM
Application	· 1" and larger hex sizes	· Small diameter aftermarket wheels · Ultra-thin design key adapter	· Additional shank for increased contact with lug · 60° conical bulge seating for added contact with wheel	· Added resistance to rust and corrosion · Ideal for increased exposure to salt water	· Radial seat wheels	Ultra Light weight for maximum performance
Seat	90° taper	60° taper	ET Conical	60° taper	Radius	60° taper

Factory Lug Nuts

Original Equipment Lug Nuts

We have expanded our lug nut selection to offer chrome and black direct replacement lugs for popular makes and models.



STAINLESS STEEL CAPPED BULGE ACORN		
Make	Thread Size	Bulk#
Cadillac/ Buick	12mm 1.50	WN-263-B
	Box Qty.	50/300



FLANGE NUT		
Make	Thread Size	Bulk#
Chevrolet/ GMC/Buick	14mm 1.50	WN-202-B
	Box Qty.	20/120



STAINLESS STEEL CAPPED DUPLEX BULGE ACORN		
Make	Thread Size	Bulk#
Chevrolet/ GMC/Buick	14mm 1.50	WN-236-B
	Box Qty.	30/180

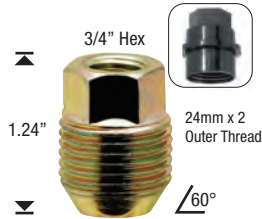

OPEN-END DUAL THREAD ACORN		
Make	Thread Size	Bulk#
Chevrolet/ Buick/ Saturn	12mm x 1.50	WN-150-B
	3/4" Black Cap	2000SCP
	3/4" Chrome Cap	2000SCP-CR
	Box Qty.	50/300



OPEN-END DUAL THREAD ACORN		
Make	Thread Size	Bulk#
Chevrolet/ GMC	7/16	2002
	1/2	2004
	12mm 1.50	2007
	14mm 1.50	2009
	9/16	2010
	7/8" Black Cap	2000CP
	7/8" Chrome Cap	2000CP-CR
Box Qty.	40/240	



OPEN-END DUAL THREAD ACORN		
Make	Thread Size	Bulk#
Chevrolet	7/16	2002S
	1/2	2004S
	12mm 1.50	2007S
	14mm 1.50	2009S
	9/16	2010S
	3/4" Black Cap	2000SCP
	3/4" Chrome Cap	2000SCP-CR
Box Qty.	50/300	

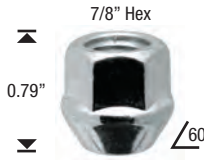

OPEN-END BULGE		
Make	Thread Size	Bulk#
Chevrolet/ GMC/Buick/ Ram	14mm 1.50	1309-1D
	9/16	1310-1D
	Box Qty.	50/300



ET BULGE		
Make	Thread Size	Bulk#
Dodge/ Chevrolet/ Buick	14mm 1.50	WN-259-B
Box Qty.	25/150	



BULGE		
Make	Thread Size	Bulk#
Dodge/ Chrysler/ Jeep	12mm 1.50	WN-074-B
Box Qty.	50/300	



DUPLEX BULGE ACORN LONG		
Make	Thread Size	Bulk#
Dodge/ Chevrolet/ Buick/ Ram/Jeep	14mm 1.50	1709DL
	14mm 1.50 (Black)	1709DLBK
Dodge	9/16	1710DL
	9/16(Black)	1710DLBK
Box Qty.	20/120	



DUPLEX BULGE ACORN		
Make	Thread Size	Bulk#
Dodge/Chevrolet/ Buick/Ram/Jeep	14mm 1.50	1709D
	14mm 1.50 (Black)	1709DBK
Dodge	9/16	1710D
	9/16(Black)	1710DBK
Ford	14mm 2.00	1750D
	14mm 2.00 (Black)	1750DBK
Box Qty.	25/150	



BULGE ACORN		
Make	Thread Size	Bulk#
Dodge/Chrysler	14mm 1.50	WN25809
Box Qty.	30/180	



STAINLESS STEEL CAPPED ET BULGE		
Make	Thread Size	Bulk#
Dodge/Chrysler	12mm 1.50	WN-181-B
Box Qty.	30/300	



ET BULGE		
Make	Thread Size	Bulk#
Dodge/Chrysler	12mm 1.50	WN-181-BC
Box Qty.	30/180	

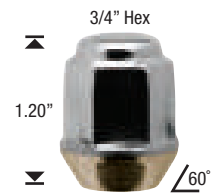

SHORT BULGE ACORN STAINLESS STEEL CAPPED		
Make	Thread Size	Bulk#
Ford	12mm 1.50	18300
Chevrolet	7/16"	WN-070-B
Box Qty.	50/300	

Factory Lug Nuts



FLANGE NUT BLACK		
Make	Thread Size	Bulk#
Ford	12mm 1.75	WN17212
	Box Qty.	50/300



SWIVEL FLANGE FLAT		
Make	Thread Size	Bulk#
Ford	1/2"	9604
	9/16"	9610
	14MM 2.0	WN-196-B
	14MM 1.50	WN-246-B
	Box Qty.	50/300



BULGE ACORN		
Make	Thread Size	Bulk#
Ford	1/2"	WN58404
	Box Qty.	30/180



BULGE ACORN		
Make	Thread Size	Bulk#
Ford	12mm 1.50	WN58307
	12mm 1.50 (Black)	WN58307BK
	Box Qty.	30/180



OPEN-END BULGE ACORN		
Make	Thread Size	Bulk#
Ford	14mm 2.0	WN-223-B
	14mm 1.5	WN98209
	Box Qty.	30/180



BULGE ACORN		
Make	Thread Size	Bulk#
Ford	14mm 1.50	WN-008-B
	14mm 1.50(Black)	WN-008-BK
	Box Qty.	30/180



BULGE ACORN		
Make	Thread Size	Bulk#
Ford	14mm 2.0	WN-288-B
	14mm 2.00(Black)	WN-288-BK
	Box Qty.	25/150



BULGE ACORN		
Make	Thread Size	Bulk#
Ford	12mm 1.50	WN-303-B
	12mm 1.50(Black)	WN-303-BK
	Box Qty.	50/300



BULGE ACORN		
Make	Thread Size	Bulk#
Ford	12mm 1.50	WN-303L-B
	Box Qty.	50/300

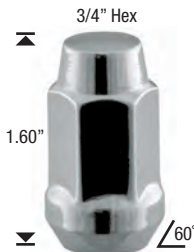

BULGE ACORN		
Make	Thread Size	Bulk#
Ford	1/2	WN-94-B
	Box Qty.	40/240



BULGE ACORN		
Make	Thread Size	Bulk#
Ford	1/2	WN-71-B
	Box Qty.	50/300



BULGE ACORN		
Make	Thread Size	Bulk#
Ford Mustang	1/2	1004M
	Box Qty.	50/300



STAINLESS STEEL CAPPED BULGE ACORN		
Make	Thread Size	Bulk#
Ford Mustang	1/2	WN-292-B
	14mm 1.50	WN00709ST
	Box Qty.	50/300

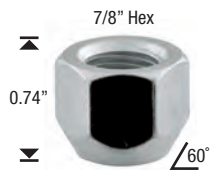

OPEN-END ACORN		
Make	Thread Size	Bulk#
Ford Van	9/16	WN-52-B
	Box Qty.	50/300



BULGE ACORN CHROME & BLACK		
Make	Thread Size	Bulk#
Ford Mustang/Lincoln	14mm 1.50	WN-007-B
	14mm 1.50 (Black)	WN-007-BK
	Box Qty.	40/240



OPEN-END BULGE ACORN		
Make	Thread Size	Bulk#
Ford/Mercury	1/2	WN-199-B
	Box Qty.	40/240

Factory Lug Nuts



OPEN-END BULGE ACORN		
Make	Thread Size	Bulk#
Ford/Mercury/Lincoln	1/2	WN-163-B
Ford/Chrysler/Lincoln	12mm 1.50	WN06307
	Box Qty.	50/300

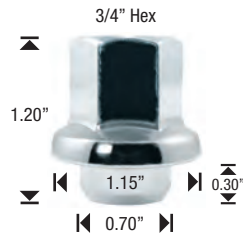

SHORT SHANK MAG		
Make	Thread Size	Bulk#
Chevrolet	7/16	5322
GM OEM / Corvette	12mm 1.50	5327
	Box Qty.	50/300



OPEN-END ACORN		
Make	Thread Size	Bulk#
GMC/Chevrolet Van and Truck	9/16	WN-53-B
	Box Qty.	50/300



RADIUS SEAT CHROME & BLACK		
Make	Thread Size	Bulk#
Honda/Acura	12mm 1.50	1907HR
	12mm 1.50 (Black)	1907HRBK
	Box Qty.	40/240



RADIUS SEAT SHORT		
Make	Thread Size	Bulk#
Honda/Acura	12mm 1.50 (radius: 12mm)	1907SR
	Box Qty.	50/300



RADIUS SEAT W/ WASHER		
Make	Thread Size	Bulk#
Honda/Acura	12mm 1.50	1907WR
	12mm 1.50 (Black)	1907WRBK
	Box Qty.	40/240



OPEN END RADIUS SEAT		
Make	Thread Size	Bulk#
Honda/Acura	12mm 1.50	WN-144-B
	Box Qty.	50/300



RADIUS SEAT CHROME & BLACK		
Make	Thread Size	Bulk#
Honda/Acura	12mm 1.50	WN-201-B
	12mm 1.50 (Black)	WN-201-BK
	Box Qty.	50/300

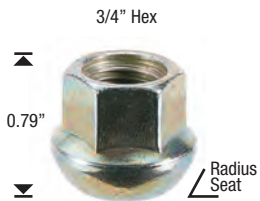

OPEN-END RADIUS SEAT HEAT TREATED		
Make	Thread Size	Bulk#
Honda/Acura	12mm 1.50	1307-1R
	14mm 1.50	1309-1R
	Box Qty.	50/300



DUPLUX RADIUS SEAT W/ ATTACHED WASHER		
Make	Thread Size	Bulk#
Honda/Acura	14mm 1.50	WN-314-B
	Box Qty.	40/240



DUPLUX RADIUS SEAT		
Make	Thread Size	Bulk#
Honda/Acura	14mm 1.50	WN-327-B
	Box Qty.	50/300



DUPLUX RADIUS SEAT CHROME & BLACK		
Make	Thread Size	Bulk#
Honda/Acura	14mm 1.50	1909DR
	14mm 1.50 (Black)	1909DRBK
	Box Qty.	20/120

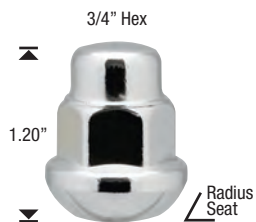

2-PC RADIUS SEAT 3/4" HEX, HEAT TREATED		
Make	Thread Size	Bulk#
Honda/Acura	14mm 1.50	1909R
	14mm 1.25 (radius: 14mm)	1925R
	Box Qty.	50/500



ACORN WITH WASHER		
Make	Thread Size	Bulk#
Kia/Hyundai	12mm 1.50	WN23807
	Box Qty.	40/240



BULGE ACORN		
Make	Thread Size	Bulk#
Hyundai/Kia	12mm 1.50	WN-315-B
	Box Qty.	40/240

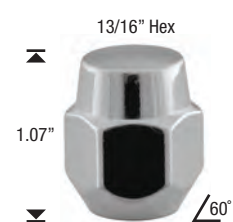

ACORN		
Make	Thread Size	Bulk#
Hyundai/Kia/Mazda	12mm 1.50	WN-141-B
	Box Qty.	50/300

Factory Lug Nuts



ACORN		
Make	Thread Size	Bulk#
Kia	12mm 1.50	WN-253-B
	Box Qty.	50/300



MAG W/ ATTACHED WASHER		
Make	Thread Size	Bulk#
Nissan	12mm 1.25	WN-210-B
	Box Qty.	40/240

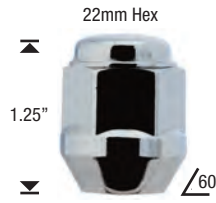

BULGE ACORN SHORT		
Make	Thread Size	Bulk#
Lexus	14mm 1.50	1709DT
	Box Qty.	40/240



OPEN-END BULGE		
Make	Thread Size	Bulk#
Nissan/Infiniti	12mm 1.25	WN26006
	Box Qty.	50/300

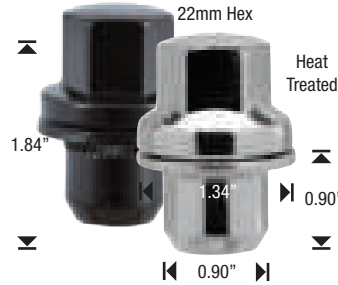

DUPLEX MAG W/ ATTACHED WASHER, CHROME & BLACK		
Make	Thread Size	Bulk#
Range Rover	14mm 1.50	5309RR
	14mm 1.50 (Black)	5309RRBK
	Box Qty.	25/150



DOME TOP ACORN		
Make	Thread Size	Bulk#
Nissan	12mm 1.25	WN-114-B
	12mm 1.25(Black)	WN-114-BK
Toyota	12mm 1.50	WN-133-B
	12mm 1.50(Black)	WN-133-BK
	Box Qty.	50/300



BULGE ACORN STAINLESS STEEL CAPPED		
Make	Thread Size	Bulk#
Jeep	7/16	1902ST
	1/2	1904ST
	12mm 1.25	1906ST
	12mm 1.50	1907ST
	14mm 1.50	1909ST
	12mm 1.75	1912ST
	Box Qty.	50/300



MEDIUM MAG W/ ATTACHED WASHER		
Make	Thread Size	Bulk#
Toyota	12mm 1.50	5307
	12mm 1.50 (Stainless Steel)	5307ST
	14mm 1.50	5309
	Box Qty.	30/180



MEDIUM MAG W/ ATTACHED WASHER BLACK		
Make	Thread Size	Bulk#
Toyota	12mm 1.50(Black)	5307BK
	Box Qty.	30/180

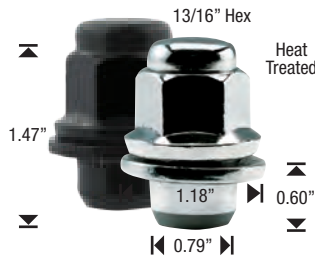

MEDIUM MAG W/ ATTACHED WASHER		
Make	Thread Size	Bulk#
Nissan/Infiniti	12mmx1.25	5306
	12mmx1.25	5306BK
	Box Qty.	30/180

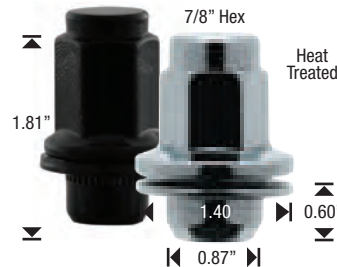

BLACK MEDIUM MAG W/ ATTACHED WASHER		
Make	Thread Size	Bulk#
Toyota/Lexus	12mm 1.50	5307DL
Lexus	14mm 1.50	5309DL
	14mm 1.50 (Black)	5309DLBK
	Box Qty.	25/150



LONG MAG DOME TOP W/ ATTACHED WASHER		
Make	Thread Size	Bulk#
Toyota	12mm 1.50	5307D
	12mm 1.50(Black)	5307DBK
	Box Qty.	40/240

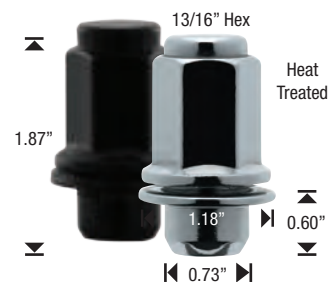

LONG MAG W/ ATTACHED WASHER		
Make	Thread Size	Bulk#
Toyota	12mm 1.50	5307L
	12mm 1.50(Black)	5307LBK
Toyota/Lexus	14mm 1.50	5309L
	14mm 1.50(Black)	5309LBK
	Box Qty.	30/180

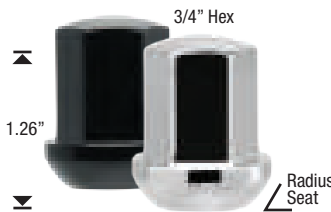

RADIUS SEAT LUG NUT HEAT TREATED, CHROME & BLACK		
Make	Thread Size	Bulk#
Porsche	14mm 1.50	1909P
	14MM 1.50(Black)	1909PBK
	Box Qty.	50/300

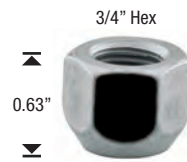

OPEN-END ACORN		
Make	Thread Size	Bulk#
Suzuki/Subaru	12mm 1.25	WN-64-BZ
	Box Qty.	50/300

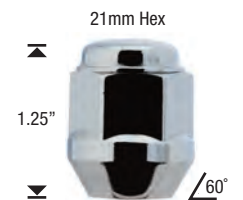

BULGE ACORN SHORT		
Make	Thread Size	Bulk#
Toyota	12mm 1.50	1707T
	Box Qty.	50/300

Factory Lug Nuts

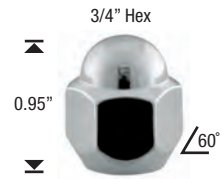
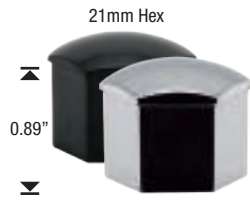

OPEN-END ACORN HEAT TREATED		
Make	Thread Size	Bulk#
Tesla	14mm 1.50	1309-1TS
	Box Qty.	50/300

LUG NUT COVER		
Make	Thread Size	Bulk#
Tesla	21mm Hex(Chrome)	2000TS-CR
	21mm Hex(Black)	2000TS-BK
	CAP REMOVER	1800PL
	Box Qty.	50/500

BULGE ACORN		
Make	Thread Size	Bulk#
Tesla	14mm 1.50	1709TS
	Box Qty.	25/150

DOME TOP ACORN		
Make	Thread Size	Bulk#
Subaru	12mm 1.25	WN-076-B
	Box Qty.	50/300

Factory Lug Nut Assortment Kit



Contains 24 skus, 93 pcs of lug nuts, covering most popular vehicles on the road today.

PART # WK-ASST-1A									
Bulk #	Make	Bulk #	Make	Bulk #	Make	Bulk #	Make	Bulk #	Make
1327	Dodge/Toyota/Chrysler/Mitsubishi	WN-133-B	Toyota	5307	Toyota	WN-259-B	Dodge/Chevrolet	1704S	Jeep
1307-1S	Ford/Dodge/Chrysler/Toyota	WN-144-B	Honda	2007S	Chevrolet/GMC/Buick	WN-196-B	Chevrolet/Buick	WN-114-B	Nissan
1707S	Chevrolet/Dodge/Chrysler/Jeep	1907WR	Honda	1309-1D	Chevrolet/GMC/Buick/Ram	2009	Chevrolet/GMC	1710DL	Dodge/Chrysler
WN-303-B	Ford	WN-201-B	Honda	1709DL	Jeep/Chevrolet/Dodge/Ram	1324	Ford/Jeep/Chevrolet	WN-288-B	Ford
WN-141-B	Hyundai	WN-181-BC	Dodge/Chrysler	WN-008-B	Ford	1304-1S	Chevrolet		

BULK# ADD "-4" FOR REFILL- PACK OF 4 PIECES

Factory Lug Bolts

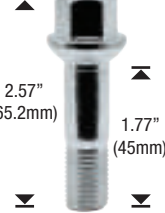
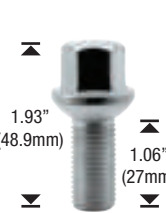
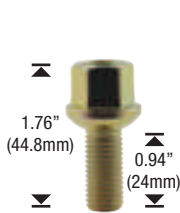

Part #	WB49807	WB31707	WB31809	WB51609	WB54909
Make	Chrysler, Mercedes-Benz	Volkswagen	Audi, Volkswagen	Mercedes-Benz	Mercedes-Benz, Maybach
Thread Size	12mmx1.5	12mmx1.5	14mmx1.5	14mmx1.5	14mmx1.5
Hex	17mm	17mm	17mm	17mm	17mm
Seat	Ball	Ball	Ball	Ball	Ball
Box Qty	30/180	30/180	30/180	30/180	30/180

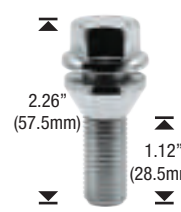
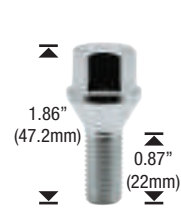

Part #	WB53225	WB57407	WB52209	WB00606	WB36707	WB49309	WB45609
Make	BMW, Mini	BMW	BMW	Chrysler, Dodge	General Motors	Volvo	Volvo
Thread Size	14mmx1.25	12mmx1.5	14mmx1.5	12mmx1.25	12mmx1.5	14mmx1.5	14mmx1.5
Hex	17mm	17mm	17mm	19mm	17mm	19mm	19mm
Seat	Cone	Cone	Cone	Cone	Cone	Cone	Cone
Box Qty	30/180	30/180	30/180	20/120	30/180	30/180	30/180

Lug Nuts

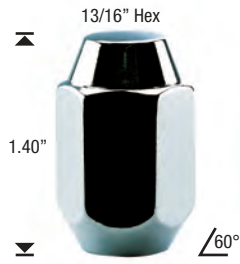

1-PC ACORN	
Thread Size	Bulk#
3/8	1001
7/16	1002
1/2	1004
12mm 1.25	1006
12mm 1.50	1007
14mm 1.50	1009
12mm 1.75	1012
Box Qty.	50/300



1-PC ACORN HEAT-TREATED	
Thread Size	Bulk#
7/16	1002H
1/2	1004H
12mm 1.25	1006H
12mm 1.50	1007H
14mm 1.50	1009H
12mm 1.75	1012H
Box Qty.	50/300



1-PC ACORN LONG	
Thread Size	Bulk#
7/16	1002L
1/2	1004L
12mm 1.25	1006L
12mm 1.50	1007L
14mm 1.50	1009L
12mm 1.75	1012L
14mm 2.00	1050L
Box Qty.	40/240



1-PC ACORN SHORT	
Thread Size	Bulk#
7/16	1002S
1/2	1004S
12mm 1.25	1006S
12mm 1.50	1007S
10mm 1.25	1010S
12mm 1.75	1012S
Box Qty.	50/300



1-PC ACORN BULGE SHORT 3/4" HEX	
Thread Size	Bulk#
1/2	1104S
12mm 1.25	1106S
12mm 1.50	1107S
14mm 1.50	1109S
Box Qty.	50/300

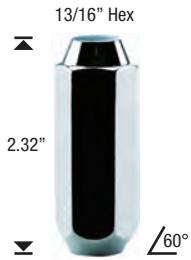

XL ACORN	
Thread Size	Bulk#
14mm 1.50	1009XL
14mm 2.00	1050XL
Box Qty.	30/180



2-PC ACORN	
Thread Size	Bulk#
7/16	1202
1/2	1204
1/2 L.H.	1205
12mm 1.25	1206
12mm 1.50	1207
14mm 1.50	1209
12mm 1.75	1212
Box Qty.	50/300



2-PC ACORN HEAT TREATED	
Thread Size	Bulk#
7/16	1402
1/2	1404
12mm 1.25	1406
12mm 1.50	1407
14mm 1.50	1409
12mm 1.75	1412
Box Qty.	50/300



BLACK ACORN	
Thread Size	Bulk#
7/16	1202BK
1/2	1204BK
12mm 1.25	1206BK
12mm 1.50	1207BK
14mm 1.50	1209BK
12mm 1.75	1212BK
Box Qty.	50/300

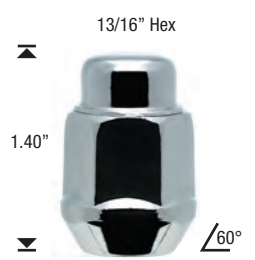

2-PC BULGE ACORN	
Thread Size	Bulk#
7/16	1702
1/2	1704
12mm 1.25	1706
12mm 1.50	1707
14mm 1.50	1709
12mm 1.75	1712
14mm 2.0	1750
9/16	1710
Box Qty.	50/300



2-PC BULGE ACORN 3/4" HEX	
Thread Size	Bulk#
7/16	1702S
1/2	1704S
10mm 1.50	1711S
12mm 1.25	1706S
12mm 1.50	1707S
14mm 1.50	1709S
9/16	1710S
12mm 1.75	1712S
14mm 2.00	1750S
Box Qty.	50/300



2-PC BULGE ACORN HEAT TREATED	
Thread Size	Bulk#
7/16	1702SH
1/2	1704SH
12mm 1.25	1706SH
12mm 1.50	1707SH
14mm 1.50	1709SH
12mm 1.75	1712SH
14mm 2.00	1750SH
Box Qty.	50/300



2-PC BLACK BULGE ACORN	
Thread Size	Bulk#
7/16	1702BK
1/2	1704BK
12mm 1.25	1706BK
12mm 1.50	1707BK
14mm 1.50	1709BK
(Add "S" for 3/4" Hex)	
Box Qty.	50/300



2-PC RED/BLUE BULGE ACORN	
Thread Size	Bulk#
7/16	1702
1/2	1704
12mm 1.25	1706
12mm 1.50	1707
14mm 1.50	1709
12mm 1.75	1712
(Add "S" for 3/4" Hex)	
(Add R=Red; BL=Blue)	
Box Qty.	50/300



BULGE ACORN LONG	
Thread Size	Bulk#
7/16	1702L
1/2	1704L
12mm 1.25	1706L
12mm 1.50	1707L
5/8	1708L
9/16	1710L
Box Qty.	40/240

Lug Nuts



XXL BULGE ACORN	
Thread Size	Bulk#
14mm 1.50	1709SXL
12mm 1.75	1712SXL
14mm 2.00	1750SXL
9/16	1710SXL
Box Qty.	30/180



1-PC BULGE ACORN	
Thread Size	Bulk#
7/16	1902S
1/2	1904S
12mm 1.25	1906S
12mm 1.50	1907S
14mm 1.50	1909S
12mm 1.75	1912S
14mm 2.00	1950S
Box Qty.	50/300



BULGE ACORN LONG 3/4 HEX	
Thread Size	Bulk#
7/16	1902SL
1/2	1904SL
9/16	1910SL
12mm 1.25	1906SL
12mm 1.50	1907SL
14mm 1.50	1909SL
12mm 1.75	1912SL
14mm 2.0	1950SL
Box Qty.	40/240



BULGE ACORN LONG 3/4 HEX BLACK	
Thread Size	Bulk#
14mm 1.50	1909SLBK
9/16	1910SLBK
Box Qty.	30/180



BULGE ACORN LONG 13/16 HEX	
Thread Size	Bulk#
7/16	1902L
1/2	1904L
9/16	1910L
12mm 1.25	1906L
12mm 1.50	1907L
14mm 1.50	1909L
12mm 1.75	1912L
14mm 2.0	1950L
Box Qty.	30/180



XL BULGE ACORN	
Thread Size	Bulk#
7/16	1902XL
1/2	1904XL
9/16	1910XL
12mm 1.25	1906XL
12mm 1.50	1907XL
14mm 1.50	1909XL
12mm 1.75	1912XL
14mm 2.00	1950XL
Box Qty.	30/180

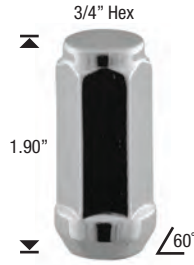

XL BULGE ACORN HEAT TREATED	
Thread Size	Bulk#
14mm 1.50	1909XLH
9/16	1910XLH
14mm 2.00	1950XLH
Box Qty.	30/180



BLACK XL BULGE ACORN	
Thread Size	Bulk#
1/2	1904XLBK
14mm 1.50	1909XLBK
9/16	1910XLBK
14mm 2.00	1950XLBK
Box Qty.	30/180



OPEN-END ACORN	
Thread Size	Bulk#
3/8	1301
7/16	1302
1/2	1304
12mm 1.25	1306
12mm 1.50	1307
12mm 1.75	1312
Box Qty.	100/600



OPEN-END ACORN	
Thread Size	Bulk#
7/16	1322
1/2	1324
12mm 1.25	1326
12mm 1.50	1327
14mm 1.50	1309
9/16	1310
Box Qty.	100/600

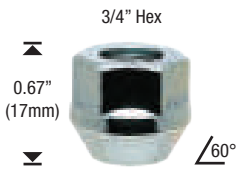

OPEN-END BULGE ACORN 17MM HEIGHT	
Thread Size	Bulk#
1/2	1304-1SA
12mm 1.25	1306-1SA
12mm 1.50	1307-1SA
14mm 1.50	1309-1SA
Box Qty.	100/600

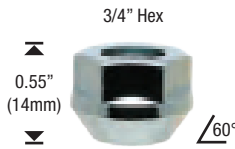

OPEN-END BULGE ACORN 14MM HEIGHT	
Thread Size	Bulk#
7/16	1302-1B
1/2	1304-1B
12mm 1.25	1306-1B
12mm 1.50	1307-1B
14mm 1.50	1309-1B
9/16	1310-1B
14mm 2.00	1350-1B
Box Qty.	100/600



OPEN-END BULGE ACORN	
Thread Size	Bulk#
1/2	1304-11
12mm 1.25	1306-11
12mm 1.50	1307-11
Box Qty.	80/480



OPEN-END BULGE	
Thread Size	Bulk#
7/16	1302-1
1/2	1304-1
12mm 1.25	1306-1
12mm 1.50	1307-1
14mm 1.50	1309-1
9/16	1310-1
12mm 1.75	1312-1
14mm 2.00	1350-1
Box Qty.	50/300

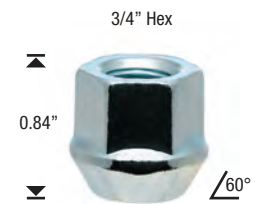

OPEN-END BULGE	
Thread Size	Bulk#
7/16	1302-1S
1/2	1304-1S
12mm 1.25	1306-1S
12mm 1.50	1307-1S
14mm 1.50	1309-1S
9/16	1310-1S
12mm 1.75	1312-1S
14mm 2.00	1350-1S
Box Qty.	50/300

Lug Nuts



OPEN-END BULGE HEAT-TREATED	
Thread Size	Bulk#
7/16	1302-1SH
1/2	1304-1SH
12mm 1.25	1306-1SH
12mm 1.50	1307-1SH
14mm 1.50	1309-1SH
9/16	1310-1SH
12mm 1.75	1312-1SH
14mm 2.00	1350-1SH
Box Qty.	50/300



DUPLEX ACORN	
Thread Size	Bulk#
7/16	3002
1/2	3004
1/2 L.H.	3005
14mm 1.50	3009
9/16	3010
5/8	3030
5/8 L.H.	3040
14mm 2.00	3050
Box Qty.	30/180



DUPLEX ACORN HEAT-TREATED	
Thread Size	Bulk#
1/2	3004H
14mm 1.50	3009H
9/16	3010H
14mm 2.00	3050H
Box Qty.	30/180

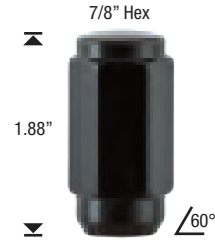

BLACK DUPLEX ACORN	
Thread Size	Bulk#
14mm 1.50	3009BK
9/16	3010BK
14mm 2.00	3050BK
Box Qty.	30/180



OPEN-END DUPLEX ACORN	
Thread Size	Bulk#
7/16	3032
1/2	3034
14mm 1.50	3039
9/16	3045
9/16 L.H.	3055
14mm 2.00	3060
5/8	3065
5/8 L.H.	3075
Box Qty.	30/180



XL DUPLEX ACORN	
Thread Size	Bulk#
1/2	3204
14mm 1.50	3209
9/16	3210
14mm 2.00	3250
Box Qty.	20/120



XXL DUPLEX ACORN	
Thread Size	Bulk#
9/16	3310
Box Qty.	20/120



DUALIE ACORN	
Thread Size	Bulk#
14mm 1.50	3109
9/16	3110
9/16 L.H.	3120
5/8	3130
5/8 L.H.	3140
Box Qty.	20/120

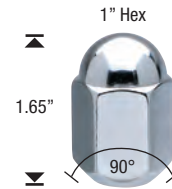

SHORT DUALIE ACORN	
Thread Size	Bulk#
14mm 1.50	3109A
9/16	3110A
Box Qty.	20/120



DUALIE ACORN W/ ATTACHED WASHER	
Thread Size	Bulk#
14mm 1.50	3109W
9/16	3110W
9/16 L.H.	3110LW
Box Qty.	20/120



BULGE ACORN HEAT TREATED	
Thread Size	Bulk#
7/16	1502
1/2	1504
12mm 1.25	1506
12mm 1.50	1507
12mm 1.50(Black)	1507BK
14mm 1.50	1509
Box Qty.	50/300



OPEN-END BULGE ACORN	
Thread Size	Bulk#
7/16	1532
1/2	1534*
12mm 1.25	1536*
12mm 1.50	1537*
14mm 1.50	1539
*Add "S" for 0.84" H	
Box Qty.	50/300



1-PC STANDARD MAG	
Thread Size	Bulk#
7/16	1740
1/2	1741
12mm 1.25	1744
12mm 1.50	1745
14mm 1.50	1749*
*1749 comes in a 0.75" Dia. & 7/8" Hex	
Uses 772 washer	
14mm uses 773 washer	
Box Qty.	50/300



OPEN-END STANDARD MAG	
Thread Size	Bulk#
7/16	1730
1/2	1731
12mm 1.25	1734
12mm 1.50	1735
14mm 1.50	1739*
*1739 comes in a 0.75" Dia. & 7/8" Hex	
Uses 772 washer	
14mm uses 773 washer	
Box Qty.	50/300

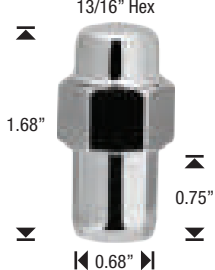

2-PCS STANDARD MAG	
Thread Size	Bulk#
7/16	8202
1/2	8204
12mm 1.25	8206
12mm 1.50	8207
Uses 772 washer	
Box Qty.	50/300

Lug Nuts

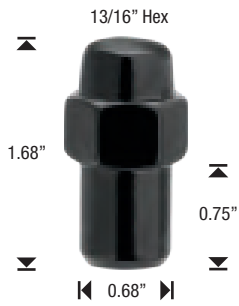

BLACK 2-PC STANDARD MAG	
Thread Size	Bulk#
7/16	8202BK
1/2	8204BK
12mm 1.25	8206BK
12mm 1.50	8207BK
Uses 772BK washer	
Box Qty.	50/300



DOME STANDARD MAG	
Thread Size	Bulk#
7/16	8102
1/2	8104
12mm 1.25	8106
12mm 1.50	8107
Uses 772 washer	
Box Qty.	50/300



1-PC SHORT SHANK MAG	
Thread Size	Bulk#
7/16	1640
1/2	1641
12mm 1.25	1644
12mm 1.50	1645
Uses 774 washer	
Box Qty.	50/300



2-PC SHORT SHANK MAG	
Thread Size	Bulk#
7/16	5202
1/2	5204
12mm 1.25	5206
12mm 1.50	5207
Uses 774 washer	
Box Qty.	50/300



OPEN-END SHORT SHANK MAG	
Thread Size	Bulk#
7/16	5102
1/2	5104
12mm 1.25	5106
12mm 1.50	5107
Uses 774 washer	
Box Qty.	50/300



DOME SHORT SHANK MAG	
Thread Size	Bulk#
7/16	5002
1/2	5004
12mm 1.25	5006
12mm 1.50	5007
Uses 774 washer	
Box Qty.	50/300



DOME MEDIUM MAG	
Thread Size	Bulk#
7/16	4002
1/2	4004
12mm 1.25	4006
12mm 1.50	4007
Uses 772 washer	
Box Qty.	50/300



OPEN-END MEDIUM MAG	
Thread Size	Bulk#
7/16	4022
1/2	4024
12mm 1.25	4026
12mm 1.50	4027
Uses 772 washer	
Box Qty.	50/300



LONG MAG	
Thread Size	Bulk#
7/16	8502
1/2	8504
12mm 1.25	8506
12mm 1.50	8507
Uses 779 or 780 washer	
Box Qty.	50/300



EXTENDED MAG	
Thread Size	Bulk#
7/16	8802
1/2	8804
12mm 1.25	8806
12mm 1.50	8807
Uses 779 or 780 washer	
Box Qty.	40/240



CRAGNAR MAG	
Thread Size	Bulk#
7/16	8852
1/2	8854
12mm 1.25	8856
12mm 1.50	8857
14mm 1.50	8859*
*#8859 comes in a 0.75" Dia. & 7/8" Hex	
Uses 779 or 780 washer	
Box Qty.	30/180

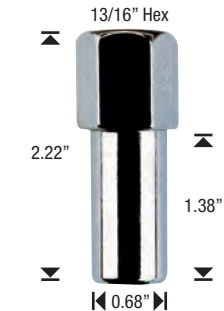

OPEN-END CRAGNAR MAG	
Thread Size	Bulk#
7/16	8852-1
1/2	8854-1
12mm 1.25	8856-1
12mm 1.50	8857-1
14mm 1.50	8859-1*
*#8859-1 comes in a 0.75" Dia. & 7/8" Hex	
Uses 779 or 780 washer	
Box Qty.	30/180



DOME DUPLEX MAG	
Thread Size	Bulk#
7/16	9002
1/2	9004
14mm 1.50	9009
9/16	9010
Uses 773 washer	
Box Qty.	40/240

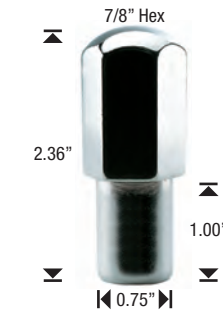

DOME XL DUPLEX MAG	
Thread Size	Bulk#
1/2	9204
14mm 1.50	9209
9/16	9210
9/16 L.H.	9220
Uses 773 washer	
Box Qty.	30/180

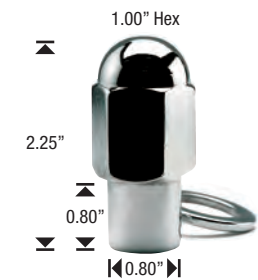

DOME MAG W/WASHER 0.80" SHANK	
Thread Size	Bulk#
5/8	9108W
14mm 1.50	9109W
9/16	9110W
14mm 2.00	9150W
Uses 773 washer	
Box Qty.	20/120

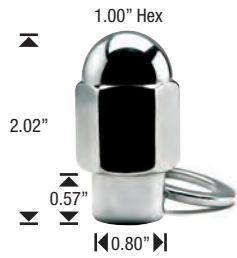

**DUALIE MAG W/WASHER
0.57" SHANK**

Thread Size	Bulk#
5/8	9308W
14mm 1.50	9309W
9/16	9310W
Uses 783 or 784 washer	
Box Qty.	20/120



ET/AP STEP MAG

Thread Size	Bulk#
7/16	7502
1/2	7504
1/2 L.H.	7505
12mm 1.25	7506
12mm 1.50	7507
Uses 783 or 784 washer	
Box Qty.	50/300



ET CONICAL

Thread Size	Bulk#
7/16	7602
1/2	7604
12mm 1.25	7606
12mm 1.50	7607
12mm 1.75	7612
Uses 785 or 786 washer	
Box Qty.	50/300



ET CONICAL OPEN-END

Thread Size	Bulk#
3/8	7601-1
7/16	7602-1
1/2	7604-1
1/2 L.H.	7605-1
12mm 1.25	7606-1
12mm 1.50	7607-1
12mm 1.75	7612-1
Uses 785 or 786 washer	
Box Qty.	50/300



ET CONICAL LONG

Thread Size	Bulk#
7/16	7602L
1/2	7604L
12mm 1.25	7606L
12mm 1.50	7607L
12mm 1.75	7612L
Uses 785 or 786 washer	
Box Qty.	30/180



ET BULGE

Thread Size	Bulk#
7/16	7802
1/2	7804
12mm 1.25	7806
12mm 1.50	7807
12mm 1.75	7812
Uses 785 or 786 washer	
Box Qty.	50/300



ET BULGE

Thread Size	Bulk#
14mm 1.50	7809
14mm 2.0	7850
Uses 773 washer	
Box Qty.	50/300

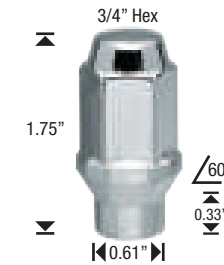

ET BULGE LONG

Thread Size	Bulk#
7/16	7802L
1/2	7804L
12mm 1.25	7806L
12mm 1.50	7807L
12mm 1.75	7812L
Uses 785 or 786 washer	
Box Qty.	40/240

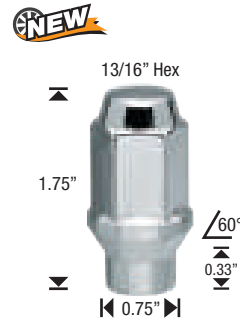

ET BULGE LONG

Thread Size	Bulk#
14mm 1.50	7809L
9/16	7810L
14mm 2.0	7850L
Uses 773 washer	
Box Qty.	40/240

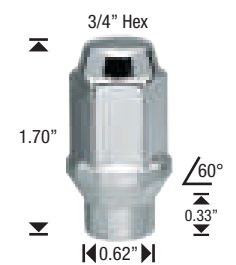

**ET BULGE LONG
HEAT TREATED**

Thread Size	Bulk#
14mm 1.50	7809LS
Uses 785 or 786 washer	
Box Qty.	40/240



**BLACK ET BULGE LONG
HEAT TREATED**

Thread Size	Bulk#
1/2	7804LSBK
12mm 1.25	7806LSBK
12mm 1.50	7807LSBK
14mm 1.50	7809LSBK
Uses 785 or 786 washer	
Box Qty.	40/240

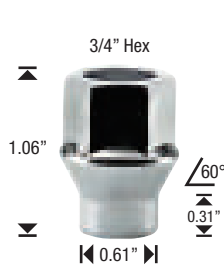

OE ET BULGE

Thread Size	Bulk#
7/16	7802-1
1/2	7804-1
12mm 1.25	7806-1
12mm 1.50	7807-1
14mm 1.50	7809-1S
12mm 1.75	7812-1
Uses 785 or 786 washer	
Box Qty.	50/300

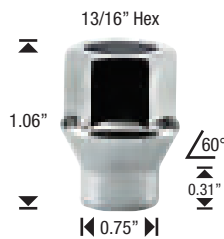

OE ET BULGE

Thread Size	Bulk#
14mm 1.50	7809-1
14mm 2.00	7850-1
9/16	7810-1
Uses 773 washer	
Box Qty.	50/300



BULLET ACORN

Thread Size	Bulk#
7/16	1932
1/2	1934
12mm 1.50	1937
14mm 1.50	1939
Uses 785 or 786 washer	
Box Qty.	50/300

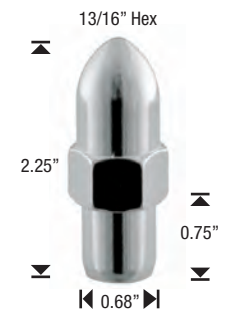

BULLET MAG

Thread Size	Bulk#
7/16	8232
1/2	8234
12mm 1.50	8237
Uses 785 or 786 washer	
Box Qty.	40/240

ATV & SST Lug Nuts

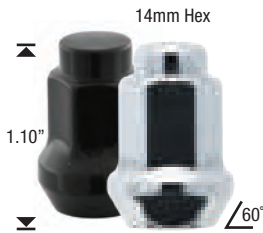

ATV BULGE	
Thread Size	Bulk#
3/8-24	1540
3/8-24(Black)	1540BK
10mm x 1.25	1510
10mm x 1.25 (Black)	1510BK
Box Qty.	50/300



ATV FLAT	
Thread Size	Bulk#
3/8-24	1540F
10mm x 1.25	1510F
Box Qty.	50/300



ATV & TRAILER BULGE 17MM HEX	
Thread Size	Bulk#
10mm x 1.25	1980N
10mm x 1.25 (Black)	1980NBK
Box Qty.	50/300



TRAILER FLAT W/WASHER	
Thread Size	Bulk#
10mm x 1.25	1980NF
12mm x 1.25	1986NF
Box Qty.	50/300

See page 18 for ATV Spike Lug Nuts

Stainless Steel Capped Lug Nuts



For Harsh Road and Weather Conditions

304 Stainless Steel
Maximum resistance to corrosion and wear

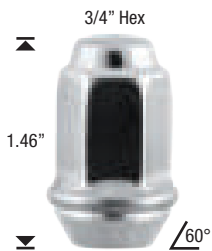

BULGE ACORN STAINLESS STEEL CAPPED	
Thread Size	Bulk#
12mm 1.50	1907STL
Box Qty.	50/300



BULGE ACORN STAINLESS STEEL CAPPED	
Thread Size	Bulk#
12mm 1.50	1907STX
Box Qty.	50/300



DUPLEX BULGE ACORN STAINLESS STEEL CAPPED	
Thread Size	Bulk#
1/2	3004ST
14mm 1.50	3009ST
9/16	3010ST
14mm 2.00	3050ST
Box Qty.	30/180



XL DUPLEX BULGE ACORN STAINLESS STEEL CAPPED	
Thread Size	Bulk#
1/2	3204ST
14mm 1.50	3209ST
9/16	3210ST
14mm 2.00	3250ST
Box Qty.	30/150

Spline/Racing Lug Nuts

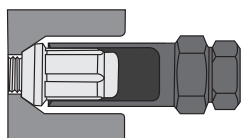

Spline Lug

- Closed-end design prevents rusting
- More stud engagement and greater seating surface

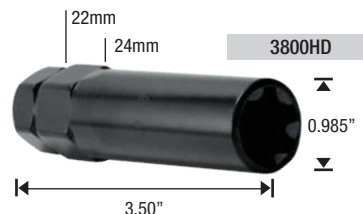
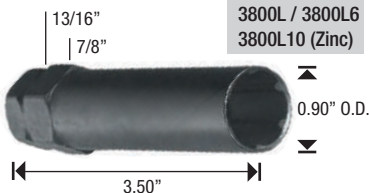
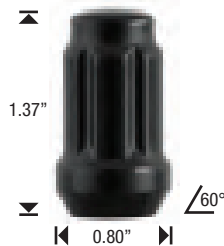
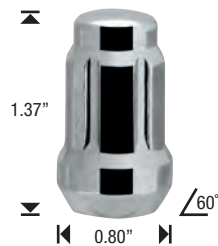

SPLINE KEY ADAPTER

Hex Size	Bulk#
3/4" & 13/16"	3800
6 Spline (Box: 20/120)	
3/4" & 13/16"	3800A7
7 Spline (Box: 20/120)	
3/4" & 13/16"	3800A10
10 Spline (Box: 10/60)	
13/16" & 7/8"	3800L
7 Spline for Duplex (Box: 10/60)	
13/16" & 7/8"	3800L6
6 Spline for Duplex (Box: 10/60)	
13/16" & 7/8"	3800L10
10 Spline for Duplex (Box: 10/60)	
22mm & 24mm	3800HD
7 Spline for Duplex (Box: 10/60)	

FOR COMPLETE SPLINE KEY SET SEE PAGE 21

SPLINE ACORN

Thread Size	Bulk#
7/16	3802
1/2	3804
12mm 1.25	3806
12mm 1.50	3807
12mm 1.75	3812
14mm 1.50 (Heat treated)	3809H
Key Adapter	3800
Box Qty.	50/300

GLOSS BLACK SPLINE ACORN

Thread Size	Bulk#
7/16	3802BK
1/2	3804BK
12mm 1.25	3806BK
12mm 1.50	3807BK
12mm 1.75	3812BK
14MM 1.50 (Heat treated)	3809HBK
Key Adapter	3800
Box Qty.	50/300

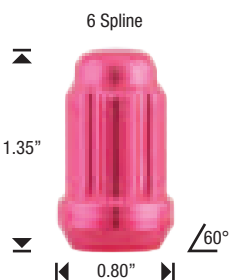
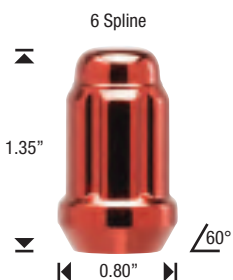

FLAT BLACK SPLINE ACORN

Thread Size	Bulk#
7/16	3802BKT
1/2	3804BKT
12mm 1.25	3806BKT
12mm 1.50	3807BKT
Key Adapter	3800
Box Qty.	100/500

BLUE SPLINE ACORN

Thread Size	Bulk#
1/2	3804BLT
12mm 1.25	3806BLT
12mm 1.50	3807BLT
Key Adapter	3800
Box Qty.	50/400

RED SPLINE ACORN

Thread Size	Bulk#
1/2	3804RDT
12mm 1.25	3806RDT
12mm 1.50	3807RDT
Key Adapter	3800
Box Qty.	50/400

MATTE BLACK SPLINE ACORN

Thread Size	Bulk#
1/2	3804MBT
12mm 1.50	3807MBT
Key Adapter	3800
Box Qty.	50/400

PINK SPLINE ACORN

Thread Size	Bulk#
1/2	3804PKT
12mm 1.50	3807PKT
Key Adapter	3800
Box Qty.	50/400

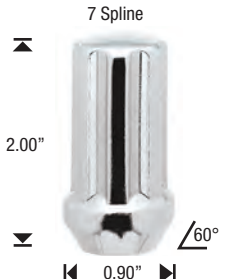
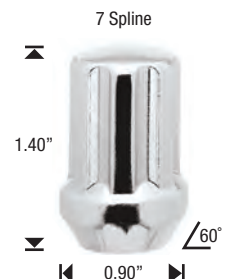
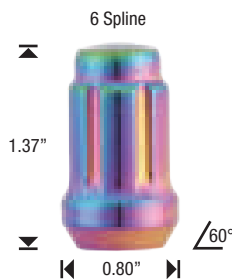

GOLD SPLINE ACORN

Thread Size	Bulk#
1/2	3804GDT
12mm 1.50	3807GDT
Key Adapter	3800
Box Qty.	50/400

NEO CHROME SPLINE ACORN

Thread Size	Bulk#
1/2	3804NEO
12mm 1.50	3807NEO
Key Adapter	3800
Box Qty.	50/300

DUPLEX SHORT SPLINE

Thread Size	Bulk#
12mm 1.50	3807D
14mm 1.50	3809D
9/16	3810D
14mm 2.00	3850D
Key Adapter	3800L
Box Qty.	50/300

BLACK DUPLEX SHORT SPLINE

Thread Size	Bulk#
12mm 1.50	3807DBK
14mm 1.50	3809DBK
9/16	3810DBK
14mm 2.00	3850DBK
Key Adapter	3800L
Box Qty.	50/300

DUPLEX SPLINE ACORN LONG

Thread Size	Bulk#
1/2"	3804L
12mm 1.50	3807L
14mm 1.50	3809L
9/16	3810L
12mm 1.75	3812L
14mm 2.00	3850L
Key Adapter	3800L
Box Qty.	30/180

Spline/Racing Lug Nuts



BLACK DUPLEX SPLINE ACORN LONG	
Thread Size	Bulk#
1/2	3804LBK
12mm 1.50	3807LBK
14mm 1.50	3809LBK
9/16	3810LBK
12mm 1.75	3812LBK
14mm 2.00	3850LBK
Key Adapter	3800L
Box Qty.	30/180



DUPLEX SPLINE	
Thread Size	Bulk#
1/2	3804LT
14mm 1.50	3809LT
9/16	3810LT
14mm 2.00	3850LT
Key Adapter	3800L
Box Qty.	30/180



DUPLEX SPLINE BLACK	
Thread Size	Bulk#
1/2	3804LTBK
14mm 1.50	3809LTBK
9/16	3810LTBK
14mm 2.00	3850LTBK
Key Adapter	3800L
Box Qty.	30/180



OPEN-END SPLINE	
Thread Size	Bulk#
7/16	3802-1
1/2	3804-1
12mm 1.25	3806-1
12mm 1.50	3807-1
Key Adapter	3800
Box Qty.	50/300

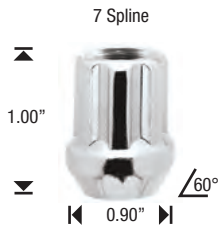

OE DUPLEX SPLINE	
Thread Size	Bulk#
14mm 1.50	3809-1D
9/16	3810-1D
12mm 1.75	3812-1D
14mm 2.00	3850-1D
Key Adapter	3800L
Box Qty.	50/300



ET SPLINE ACORN	
Thread Size	Bulk#
7/16	3802ET
1/2	3804ET
12mm 1.25	3806ET
12mm 1.50	3807ET
14mm 1.50 (Heat Treated)	3809HET
12mm 1.75	3812ET
Key Adapter	3800
Box Qty.	50/300



DUPLEX ET SPLINE ACORN	
Thread Size	Bulk#
14mm 1.50	3809ET
14mm 2.0	3850ET
Key Adapter	3800L
Box Qty.	50/300



BLACK ET SPLINE ACORN	
Thread Size	Bulk#
12mm 1.25	3806ETBK
12mm 1.50	3807ETBK
14mm 1.50 (Heat Treated)	3809HETBK
Key Adapter	3800
Box Qty.	50/300

Racing Lug Nuts

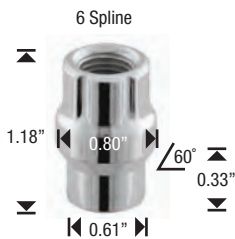

OPEN-END ET SPLINE	
Thread Size	Bulk#
7/16	3802-1ET
1/2	3804-1ET
12mm 1.25	3806-1ET
12mm 1.50	3807-1ET
Key Adapter	3800
Box Qty.	50/300



OPEN-END ET SPLINE	
Thread Size	Bulk#
14mm 1.50	3809-1ET
14mm 2.00	3850-1ET
Key Adapter	3800L
Box Qty.	50/300



OPEN-END BULGE	
Thread Size	Bulk#
1/2	1904-1S
12mm 1.25	1906-1S
12mm 1.50	1907-1S
14mm 1.50	1909-1S
Key Adapter	3800L
Box Qty.	30/180



OPEN-END BULGE BLACK	
Thread Size	Bulk#
1/2	1904-1SBK
12mm 1.25	1906-1SBK
12mm 1.50	1907-1SBK
14mm 1.50	1909-1SBK
Key Adapter	3800L
Box Qty.	30/180

Spike Lug Nuts



NEW



NEW



SPIKE LUG NUT 6"	
Thread Size	Bulk #
14mm 1.50	2909L
9/16	2910L
14mm 2.00	2950L
Key Adapter	2900L
Box Qty.	24/96

BLACK SPIKE LUG NUT 6"	
Thread Size	Bulk #
14mm 1.50	2909LBK
9/16	2910LBK
14mm 2.00	2950LBK
Key Adapter	2900L
Box Qty.	24/96

SPIKE KEY ADAPTER		
Hex Size	Bulk#	Box Qty.
3/4" & 13/16"	3900	20/120
1/2" Dr.	3800XL	10/60
1/2" Dr.	2900BK	10/60
13/16" & 7/8"	2900L	10/30



DUPLEX SPLINE SPIKE	
Thread Size	Bulk #
1/2	3804XL
12mm 1.25	3806XL
12mm 1.50	3807XL
14mm 1.50	3809XL
9/16	3810XL
14mm 2.00	3850XL
Key Adapter	3800XL
Box Qty.	24/144

BLACK DUPLEX SPLINE SPIKE	
Thread Size	Bulk #
1/2	3804LBK
12mm 1.25	3806LBK
12mm 1.50	3807LBK
14mm 1.50	3809LBK
9/16	3810LBK
14mm 2.00	3850LBK
Key Adapter	3800XL
Box Qty.	24/144

Spike Lug Nuts

NEW



NEW



NEW



NEW



SPIKE LUG NUT 4.46"	
Thread Size	Bulk #
1/2"	2904
12mm 1.25	2906
12mm 1.50	2907
14mm 1.50	2909
9/16	2910
14mm 2.00	2950
Key Adapter	2900BK
Box Qty.	20/120

BLACK SPIKE LUG NUT 4.46"	
Thread Size	Bulk #
1/2"	2904BK
12mm 1.25	2906BK
12mm 1.50	2907BK
14mm 1.50	2909BK
9/16	2910BK
14mm 2.00	2950BK
Key Adapter	2900BK
Box Qty.	20/120

RED SPIKE LUG NUT	
Thread Size	Bulk #
1/2"	2904RD
14mm 1.50	2909RD
9/16	2910RD
14mm 2.00	2950RD
Key Adapter	2900BK
Box Qty.	20/120

BLUE SPIKE LUG NUT	
Thread Size	Bulk #
1/2"	2904BL
14mm 1.50	2909BL
9/16	2910BL
14mm 2.00	2950BL
Key Adapter	2900BK
Box Qty.	20/120

ATV Spike Lug Nuts



ATV SPIKE (7-SIDE)	
Thread Size	Bulk#
12mm 1.25	3916
12mm 1.50	3917
3/8	3940
10mm 1.25	3980
Key Adapter	3900
Box Qty.	50/300

BLACK ATV SPIKE (7-SIDE)	
Thread Size	Bulk#
12mm 1.25	3916BK
12mm 1.50	3917BK
3/8	3940BK
10mm 1.25	3980BK
Key Adapter	3900
Box Qty.	50/300

Spike Lug Nuts



- Made of 7075 aluminum
- Spikes are extremely light weight at 18.66 grams
- Lugs are made of cold forged steel
- Twist off design allows for interchangeable colors of spikes



ALUMINUM SPIKE	
Thread Size	Bulk#
BLUE NEW	1900BL
GRAY NEW	1900GY
Silver	1900
Black	1900BK
Red	1900RD
Neo Chrome	1900NEO
Box Qty.	100/600

SPIKE LUG NUTS	
Thread Size	Bulk#
1/2	1914
12mm 1.25	1916
12mm 1.50	1917
14mm 1.50	1919
Box Qty.	50/300

BLACK SPIKE LUG NUTS	
Thread Size	Bulk#
1/2	1914BK
12mm 1.25	1916BK
12mm 1.50	1917BK
14mm 1.50	1919BK
Box Qty.	50/300

RED SPIKE LUG NUTS	
Thread Size	Bulk#
1/2	1914RD
12mm 1.50	1917RD
14mm 1.50	1919RD
Box Qty.	50/300

NEO CHROME SPIKE LUG NUTS	
Thread Size	Bulk#
1/2	1914NEO
12mm 1.50	1917NEO
14mm 1.50	1919NEO
Box Qty.	50/300

Tuner Lug Nuts

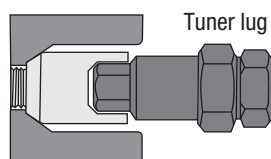

* Fits wheels with small diameter recesses



2800D



2800



2800S

TUNER SOCKET ADAPTER

Thread Size	Box Quantity	Bulk#
3/4" & 13/16"	30/180	2800
21mm & 22mm	30/300	2800D
17mm & 19mm	30/180	2800S
13/16" & 7/8"	20/200	5400

6-Sided Pattern



TUNER ACORN HEAT TREATED

Thread Size	Bulk#
7/16	2802
1/2	2804
12mm 1.25	2806
12mm 1.50	2807
14mm 1.50	2809
12mm 1.75	2812
14mm 2.0	2850
Socket Adapter	2800
Socket Adapter	2800S
Box Qty.	50/300

TUNER ACORN LONG HEAT TREATED

Thread Size	Bulk#
14mm 1.50	2809SL
14MM 1.50(Black)	2809SLBK
Socket Adapter	2800
Socket Adapter	2800D
Socket Adapter	2800S
Box Qty.	50/300

10-Sided Pattern



TUNER LOCKS HEAT TREATED

Thread Size	Bulk#
7/16	48200A
1/2	48400A
12mm 1.25	48600A
12mm 1.50	48700A
14mm 1.50	48900A
12mm 1.75	48120A
14mm 2.00	48500A
Key	48000
Sold by piece only	

Washers & Wheel Inserts

Washers



Part#	624	770	772	772BK	772C
Application	V.W. Washer	Standard Mag Stainless	Standard Mag	Standard Mag Black	Standard Mag Chrome
	100/600	250/1500	400/2400	400/2400	400/2400

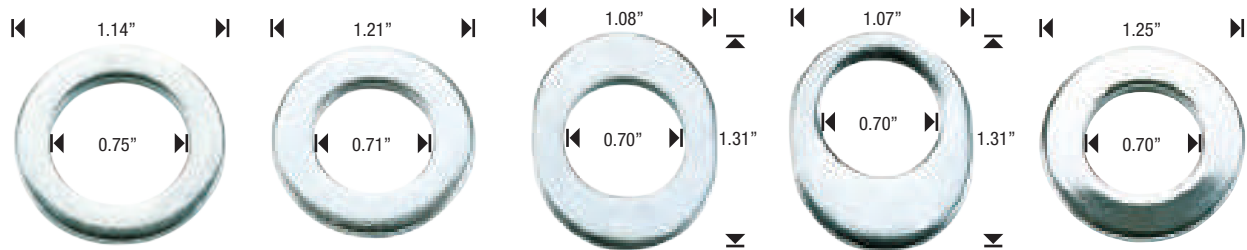

Part#	773	774	777	778	779
Application	Duplex Mag	Short Shank Mag	Keystone Mag Center	Keystone Mag Off-Center	Cragar Mag Center
	300/1800	250/1500	250/1500	250/1500	200/1200

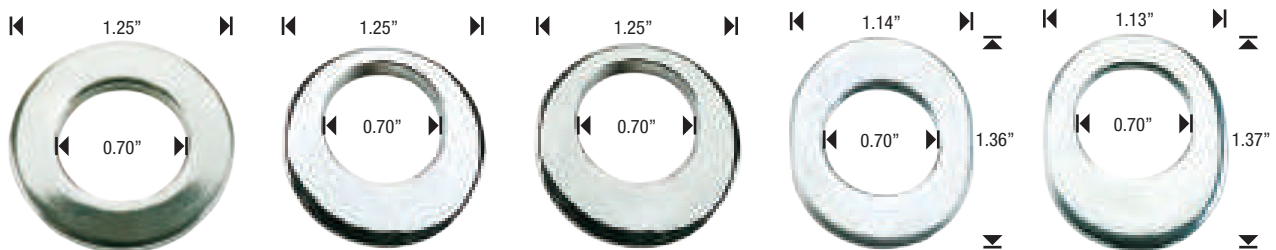

Part#	779SS	780	780SS	781	782
Application	"Cragar Mag Center Stainless Steel"	Cragar Mag Off-Center	"Cragar Mag Off-Center Stainless Steel"	ET Flat Center	ET Flat Off-Center
	150/600	200/1200	100/600	200/1200	200/1200

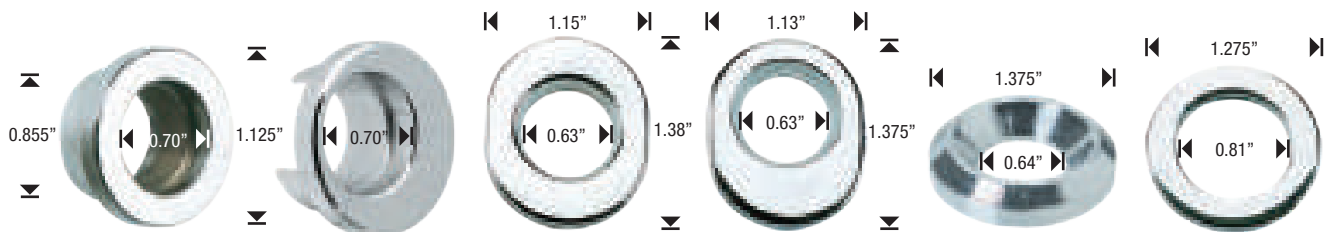

Part#	783	784	785	786	787	789
Application	AP Bushing Center	AP Bushing Off-Center	ET Conical Center	ET Conical Off-Center	Dualie Washer	Dualie Mag Washer-Chrome
	100/600	100/600	200/1200	200/1200	100/600	200/1200

Wheel Inserts



Part#	Description
W1620	0.63" ID 0.83" OD Stud Hole Nickel Finish
Box Qty.	100/600



Part#	Description
W1630	0.63" ID 0.83" OD Stud Hole Black Finish
Box Qty.	100/600



Part#	Description
W1660	0.63" ID 1.02" OD Stud Hole Nickel Finish
Box Qty.	100/600

About our wheel locks:

- Our anti-theft wheel locks are lug nuts that require uniquely patterned keys for fastening and removal.
- Each wheel lock is manufactured for maximum durability and protection from environmental hazards, corrosion and theft.
- Triple plating - Two layers of nickel and one layer of chrome provide our locks with a radiant appearance and durable protection from harsh environment conditions.
- Specially formulated corrosion protection is applied to our chrome plated fasteners to meet or exceed the industry's standard salt spray testing.
- Each lock set comes with a key card for easy key identification and replacement.

All Wheel Locks Include: 4 Lock Nuts And One Key Adapter

Socket Key Wheel Locks

Puzzle Key Wheel Locks



Dual Hex Socket Key
(3/4 & 13/16)



Dual Hex Puzzle Key
(3/4 & 13/16)

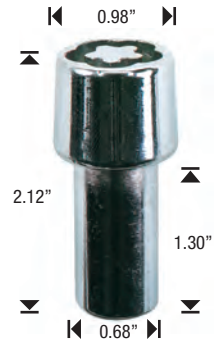

ACORN	
Thread Size	Bulk#
7/16	40200
1/2	40400
12mm 1.25	40600
12mm 1.50	40700
14mm 1.50	40900

DUPLIX ACORN	
Thread Size	Bulk#
1/2	40430
9/16	41030
14mm 1.50	40930

MAG	
Thread Size	Bulk#
7/16	42200
1/2	42400
12mm 1.25	42600
12mm 1.50	42700
12mm 1.75	42800
14mm 1.50	42900*

*0.75" Diameter

DUPLIX MAG	
Thread Size	Bulk#
9/16	41090
1/2	42490
14mm 1.50	42930

XL MAG	
Thread Size	Bulk#
7/16	46200
1/2	46400
12mm 1.25	46600
12mm 1.50	46700



SHORT SHANK MAG	
Thread Size	Bulk#
7/16	44200
1/2	44400
12mm 1.25	44600
12mm 1.50	44700

ET CONICAL LOCKS	
Thread Size	Bulk#
7/16	47200
1/2	47400
12mm 1.25	47600
12mm 1.50	47700

Spline Lug Nut Master Key Set

PART# WK-ASST-KEY1 **NEW**



Wheel Lock Master Key Set

PART# KEY-ASST1 **NEW**



Wheel Locks

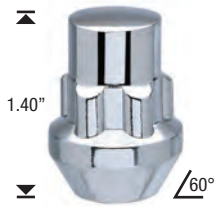

ACORN	
Thread Size	Bulk#
7/16	40200S
9/16	40300S
1/2	40400S
1/2 (5pc set)	40400S-5
12mm 1.25	40600S
12mm 1.50	40700S
12mm 1.75	40800S
14mm 1.50	40900S
14mm 2.00	40500S



BLACK ACORN	
Thread Size	Bulk#
7/16	40200SBK
1/2	40400SBK
1/2 (5pc set)	40400SBK-5
12mm 1.25	40600SBK
12mm 1.50	40700SBK
14mm 1.50	40900SBK



ACORN LONG	
Thread Size	Bulk#
7/16	40200SL
9/16	40300SL
1/2	40400SL
12mm 1.25	40600SL
12mm 1.50	40700SL
12mm 1.75	40800SL
14mm 1.50	40900SL

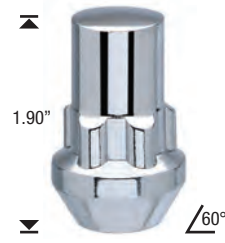

ACORN X LONG	
Thread Size	Bulk#
7/16	40200XL
9/16	40300XL
1/2	40400XL
12mm 1.25	40600XL
12mm 1.50	40700XL
12mm 1.75	40800XL
14mm 1.50	40900XL
14mm 1.50 (5pc set)	40900XL-5
14mm 2.00	40500XL

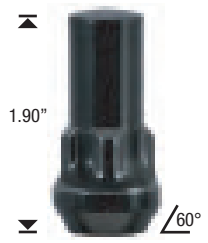

BLACK ACORN X LONG	
Thread Size	Bulk#
9/16	40300XLBK
14mm 1.50	40900XLBK
14mm 2.00	40500XLBK



ACORN XX LONG	
Thread Size	Bulk#
9/16	40300SXL
12mm 1.75	40800SXL
14mm 1.50	40900SXL
14mm 2.00	40500SXL

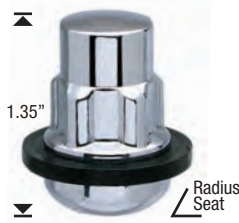

HONDA ACORN RADIUS SEAT W/GROOVE	
Thread Size	Bulk#
12mm 1.50	40700SR
Note: Washer removable	



OPEN-END ACORN	
Thread Size	Bulk#
7/16	41200
9/16	41300
1/2	41400
12mm 1.25	41600
12mm 1.50	41700
12mm 1.75	41800
14mm 1.50	41900
14mm 2.00	41500



OPEN-END ACORN	
Thread Size	Bulk#
9/16	41300XL
14mm 1.50	41900XL
14mm 2.00	41500XL



OPEN-END ACORN W/17MM HEX KEY	
Thread Size	Bulk#
7/16	43200
1/2	43400
12mm 1.25	43600
12mm 1.50	43700



HONDA OPEN END ACORN RADIUS SEAT	
Thread Size	Bulk#
12mm 1.50	41700R
14mm 1.50	41900R



OPEN-END ET BULGE	
Thread Size	Bulk#
7/16	41200ET
1/2	41400ET
12mm 1.25	41600ET
12mm 1.50	41700ET

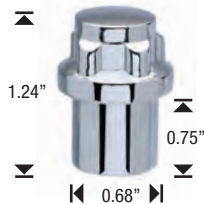

MAG	
Thread Size	Bulk#
7/16	42200S
1/2	42400S
12mm 1.25	42600S
12mm 1.50	42700S

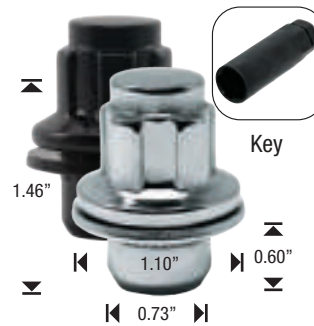

TOYOTA/NISSAN MEDIUM MAG W/WASHER	
Thread Size	Bulk#
7/16	45200
1/2	45400
12mm 1.25	45600
12mm 1.50	45700
12mm 1.50(Black)	45700BK

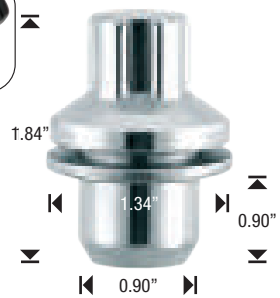

RANGE ROVER	
Thread Size	Bulk#
14mm 1.50	45900RR

Lug Bolts - Cone Seat (Box 30/180)

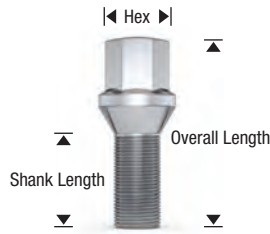

1816



NEW

NEW

NEW

NEW

Bulk #	Thread Size	Hex	Shank Length		Overall Length		Finish
			Inches	mm	Inches	mm	
1821F	12mm x 1.25	17mm	0.98	25	2.10	53	
1821	12mm x 1.25	17mm	1.10	28	2.22	56	
1821BK	12mm x 1.25	17mm	1.10	28	2.22	56	Black
1821M	12mm x 1.25	17mm	1.30	33	2.42	61	
1821L	12mm x 1.25	17mm	1.55	39	2.67	68	
1814S	12mm x 1.25	19mm	0.93	24	2.05	52	
1814	12mm x 1.25	19mm	1.10	28	2.22	56	
1816	12mm x 1.25	19mm	1.22	31	2.02	51	see image
1814L	12mm x 1.25	19mm	1.55	39	2.67	68	
1806SA	12mm x 1.50	17mm	0.86	22	1.98	50	
1806	12mm x 1.50	17mm	0.93	24	2.05	52	
1806BK	12mm x 1.50	17mm	0.93	24	2.05	52	Black
1807	12mm x 1.50	17mm	1.10	28	2.22	56	
1807BK	12mm x 1.50	17mm	1.10	28	2.22	56	Black
1807B	12mm x 1.50	17mm	1.18	30	2.30	58	
1807BBK	12mm x 1.50	17mm	1.18	30	2.30	58	Black
1807M	12mm x 1.50	17mm	1.30	33	2.42	61	
1805	12mm x 1.50	17mm	1.55	39	2.60	66	
1805BK	12mm x 1.50	17mm	1.55	39	2.60	66	Black
1805LS	12mm x 1.50	17mm	1.97	50	3.09	78	
1805L	12mm x 1.50	17mm	2.36	60	3.49	89	
1817	12mm x 1.50	19mm	1.10	28	2.22	56	
1801	12mm x 1.75	17mm	0.93	24	2.05	52	
1825S	14mm x 1.25	17mm	0.93	24	1.99	51	
1825SBK	14mm x 1.25	17mm	0.93	24	1.99	51	Black
1825	14mm x 1.25	17mm	1.10	28	2.16	55	
1825BK	14mm x 1.25	17mm	1.10	28	2.16	55	Black
1825B	14mm x 1.25	17mm	1.14	29	2.19	56	
1825BBK	14mm x 1.25	17mm	1.14	29	2.19	56	Black
1825MS	14mm x 1.25	17mm	1.26	32	2.32	59	
1825L	14mm x 1.25	17mm	1.57	40	2.60	66	
1825LBK	14mm x 1.25	17mm	1.57	40	2.60	66	Black
1825C	14mm X 1.25	17mm	1.77	45	2.83	72	
1825LS	14mm x 1.25	17mm	1.97	50	3.03	77	
1820SA	14mm x 1.50	17mm	0.86	22	1.92	49	
1820S	14mm x 1.50	17mm	0.93	24	1.99	51	
1820SBK	14mm x 1.50	17mm	0.93	24	1.99	51	Black
1820	14mm x 1.50	17mm	1.10	28	2.16	55	
1820BK	14mm x 1.50	17mm	1.10	28	2.16	55	Black
1820B	14mm x 1.50	17mm	1.18	30	2.24	57	
1820BBK	14mm x 1.50	17mm	1.18	30	2.24	57	Black
1820MS	14mm x 1.50	17mm	1.25	32	2.30	58	
1820M	14mm x 1.50	17mm	1.30	33	2.36	60	
1820L	14mm x 1.50	17mm	1.55	39	2.61	66	
1820LBK	14mm x 1.50	17mm	1.55	39	2.61	66	Black
1820A	14mm x 1.50	17mm	1.89	48	2.95	75	
1820LS	14mm x 1.50	17mm	1.97	50	3.03	77	
1820ML	14mm x 1.50	17mm	2.17	55	3.23	82	
1820XL	14mm x 1.50	17mm	2.36	60	3.42	87	
1822	14mm x 1.50	19mm	1.10	28	2.15	55	
1827	15mm x 1.25	17mm	1.10	28	2.16	55	
1827BK	15mm x 1.25	17mm	1.10	28	2.16	55	Black
1827M	15mm x 1.25	17mm	1.30	33	2.36	60	
1827MBK	15mm x 1.25	17mm	1.30	33	2.36	60	Black
1860	16mm x 1.50	21mm	1.26	32	2.52	64	
1860BK	16mm x 1.50	21mm	1.26	32	2.52	64	Black

Lug Bolts

About our Lug Bolts

- Designed to fit most European models.
- Chrome plated lug bolts are through-hardened 10.9 grade steel for maximum durability and tensile strength.
- Spline & Tuner lug bolts are engineered for after-market wheels with small diameter and deep lug bolts.

Lug Bolts - Ball Seat (Box 30/180)

All ball seats are 13mm radius unless otherwise stated

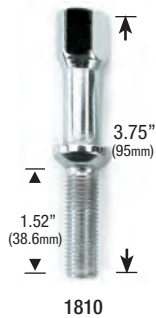
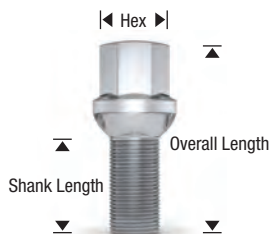

Bulk #	Thread Size	Hex	Radius	Shank Length		Overall Length		Finish
				inches	mm	inches	mm	
1808SA	12mm x 1.50	17mm	13mm	0.86	22.0	1.86	47.0	
1808S	12mm x 1.50	17mm	13mm	0.93	24.0	1.93	49.0	
1804	12mm x 1.25	17mm	13mm	1.10	28.0	2.10	53.0	
1808	12mm x 1.50	17mm	13mm	1.10	28.0	2.10	53.0	
1808BK	12mm x 1.50	17mm	13mm	1.10	28.0	2.10	53.0	Black
1808M	12mm x 1.50	17mm	13mm	1.38	35.0	2.38	60.0	
1810	12mm x 1.50	17mm	13mm	1.52	39.0	3.75	95.0	see image
1804L	12mm x 1.25	17mm	13mm	1.55	39.0	2.55	65.0	
1808L	12mm x 1.50	17mm	13mm	1.55	39.0	2.55	65.0	
1808LS	12mm x 1.50	17mm	13mm	1.97	50.0	2.97	75.0	
1808ML	12mm x 1.50	17mm	13mm	2.17	55.0	3.17	81.0	
1808XL	12mm x 1.50	17mm	13mm	2.36	60.0	3.36	85.0	
1802	12mm x 1.75	17mm	13mm	0.93	24.0	1.93	49.0	
1809SA	14mm x 1.50	17mm	13mm	0.86	22.0	1.86	47.0	
1809S	14mm x 1.50	17mm	13mm	0.93	24.0	1.93	49.0	
1809	14mm x 1.50	17mm	13mm	1.10	28.0	2.10	53.0	
1809BK	14mm x 1.50	17mm	13mm	1.10	28.0	2.10	53.0	Black
1809B	14mm x 1.50	17mm	13mm	1.16	29.0	2.21	56.0	
1826BR13	14mm x 1.25	17mm	13mm	1.20	30.0	2.11	54.0	
1826BR13BK	14mm x 1.25	17mm	13mm	1.20	30.0	2.11	54.0	Black
1809M	14mm x 1.50	17mm	13mm	1.30	33.0	2.30	58.0	
1809L	14mm x 1.50	17mm	13mm	1.55	39.0	2.55	65.0	
1809C	14mm x 1.50	17mm	13mm	1.77	45.0	2.75	70.0	
1809LS	14mm x 1.50	17mm	13mm	1.97	50.0	2.97	75.0	
1809ML	14mm x 1.50	17mm	13mm	2.17	55.0	3.17	81.0	
1809XL	14mm x 1.50	17mm	13mm	2.36	60.0	3.36	85.0	
1809R14	14mm x 1.50	17mm	14mm	1.10	28.0	2.00	51.0	
1830	14mm x 1.50	19mm	14mm	1.77	45.0	2.76	70.0	

Short Head Lug Bolts - Cone Seat (Box 30/180)



Bulk #	Thread Size	Hex	Shank Length		Overall Length		Finish
			inches	mm	inches	mm	
1811	12mm x 1.50	17mm	1.02	26	1.74	44	
1812	14mm x 1.50	17mm	1.02	26	1.74	44	



Bulk #	1800BP	1800CP	1800PL
Color	Black Plastic	Chrome Plastic	Cap Puller
Hex	17mm	17mm	

Spline Lug Bolt Key Adapters

6 Spline Adapters



Bulk #	Hex Size
3800	3/4" & 13/16"



Bulk #	Hex Size
3800S	17mm & 19mm

Spline Lug Bolt - Cone Seat (Box 30/180)



NEW

NEW

NEW

NEW

NEW

NEW

Bulk #	Thread Size	Shank Length		Overall Length		Finish
		Inches	mm	Inches	mm	
1821SSPBK	12mm x 1.25	0.93	24	2.09	53	Black
1821SP	12mm x 1.25	1.10	28	2.28	58	
1821SPBK	12mm x 1.25	1.10	28	2.28	58	Black
1806ASP	12mm x 1.50	0.86	22	2.02	51	
1806SP	12mm x 1.50	0.93	24	2.09	53	
1806SPBK	12mm x 1.50	0.93	24	2.09	53	Black
1807SP	12mm x 1.50	1.10	28	2.28	58	
1807SPBK	12mm x 1.50	1.10	28	2.28	58	Black
1807BSP	12mm x 1.50	1.18	30	2.36	60	
1807BSPBK	12mm x 1.50	1.18	30	2.36	60	Black
1807CSP	12mm x 1.50	1.25	32	2.43	62	
1805SP	12mm x 1.50	1.57	40	2.79	71	
1805SPBK	12mm x 1.50	1.57	40	2.79	71	Black
1805LSSP	12mm x 1.50	1.97	50	3.15	80	
1825SSP	14mm x 1.25	0.93	24	2.06	52	
1825SP	14mm x 1.25	1.10	28	2.20	56	
1825SPBK	14mm x 1.25	1.10	28	2.20	56	Black
1825LSP	14mm x 1.25	1.57	40	2.69	68	
1825LSSP	14mm x 1.25	1.97	50	3.15	80	
1820SSP	14mm x 1.50	0.93	24	2.11	54	
1820SP	14mm x 1.50	1.10	28	2.28	58	
1820SPBK	14mm x 1.50	1.10	28	2.28	58	Black
1820BSP	14mm x 1.50	1.18	30	2.36	60	
1820CSP	14mm x 1.50	1.25	32	2.43	62	
1820LSP	14mm x 1.50	1.57	40	2.69	68	
1820LSPBK	14mm x 1.50	1.57	40	2.69	68	Black
1820LSSP	14mm x 1.50	1.97	50	3.21	82	
1827SP	15mm x1.25	1.10	28	2.20	56	
1827SPBK	15mm x1.25	1.10	28	2.20	56	Black
1827SP40	15mm x1.25	1.57	40	2.69	68	
1827SPBK40	15mm x1.25	1.57	40	2.69	68	Black
1827SP50	15mm x1.25	1.97	50	3.21	82	
1827SPBK50	15mm x1.25	1.97	50	3.21	82	Black

Tuner Bolt Locks Key Adapters



Bulk #	Hex Size
48000	3/4" & 13/16"



Bulk #	Hex Size
48000S	17mm & 19mm

Tuner Bolt Locks - Cone Seat (Box 6/36)



Bulk #	Thread Size	Shank Length		Overall Length		Finish
		Inches	mm	Inches	mm	
41806T	12mm x 1.50	0.93	24	2.00	51	
41807T	12mm x 1.50	1.10	28	2.20	56	
41820ST	14mm x 1.50	0.93	24	2.00	51	
41820T	14mm x 1.50	1.10	28	2.20	56	

Lug Bolts & Bolt Locks

Tuner Lug Bolt Key Adapters



Bulk #	Hex Size
2800	3/4" & 13/16"

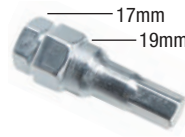

Bulk #	Hex Size
2800S	17mm & 19mm

Tuner Lug Bolts - Cone Seat (Box 30/180)

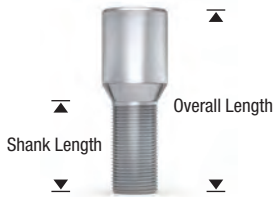

Bulk #	Thread Size	Shank Length		Overall Length		Finish
		Inches	mm	Inches	mm	
1814T	12mm x 1.25	1.10	28	2.20	56	
1806T	12mm x 1.50	0.93	24	2.00	51	
1807T	12mm x 1.50	1.10	28	2.20	56	
1807 TSH30	12mm x 1.50	1.18	30	2.24	57	
1807TL	12mm x 1.50	1.25	32	2.35	60	
1807TSH35	12mm x 1.50	1.38	35	2.44	62	
1807 TSH40	12mm x 1.50	1.57	40	2.63	67	
1807TXL	12mm x 1.50	2.36	60	3.45	88	
1824T	12mm X 1.75	1.02	26	2.09	53	
1820ST	14mm x 1.50	0.93	24	2.00	51	
1820T	14mm x 1.50	1.10	28	2.20	56	
1820 TSH30	14mm x 1.50	1.18	30	2.24	57	
1820TL	14mm x 1.50	1.26	32	2.35	60	
1820TX	14mm x 1.50	1.38	35	2.45	62	
1820TXL	14mm x 1.50	1.57	40	2.65	67	

Bolt Locks - Cone Seat (Box 6/36)

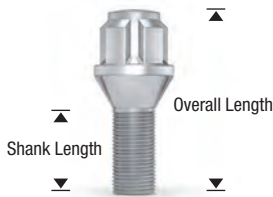

**Each set includes
4 bolt locks and one
17mm/19mm key adapter**



Bulk #	Thread Size	Shank Length		Overall Length		Finish
		Inches	mm	Inches	mm	
41803	12mm x 1.25	1.10	28	2.17	55	
41806	12mm x 1.50	0.93	24	2.02	51	
41806BK	12mm x 1.50	0.93	24	2.02	51	Black
41807	12mm x 1.50	1.10	28	2.17	55	
41807BK	12mm x 1.50	1.10	28	2.17	55	Black
41805	12mm x 1.50	1.55	39	2.55	65	
41801	12mm x 1.75	0.93	24	2.02	51	
41825S	14mm x 1.25	0.93	24	1.86	47	
41825	14mm x 1.25	1.10	28	2.02	51	
41825BK	14mm x 1.25	1.10	28	2.02	51	Black
41825L	14mm x 1.25	1.57	40	2.60	66	
41825LBK	14mm x 1.25	1.57	40	2.60	66	Black
41820S	14mm x 1.50	0.93	24	2.02	51	
41820	14mm x 1.50	1.10	28	2.13	54	
41820BK	14mm x 1.50	1.10	28	2.13	54	Black
41820MS	14mm x 1.50	1.25	32	2.21	56	
41820L	14mm x 1.50	1.55	39	2.55	65	

Bolt Locks - Ball Seat (Box 6/36)



Bulk #	Thread Size	Shank Length		Overall Length		Finish
		Inches	mm	Inches	mm	
41804	12mm x 1.25	1.10	28	1.99	51	
41808	12mm x 1.50	1.10	28	1.99	51	
41808L	12mm x 1.50	1.55	39	2.44	62	
41802	12mm x 1.75	0.93	24	1.85	47	
41809S	14mm x 1.50	0.93	24	1.85	47	
41809	14mm x 1.50	1.10	28	1.96	50	
41809BK	14mm x 1.50	1.10	28	1.96	50	Black
41809M	14mm x 1.50	1.30	33	2.10	53	
41809L	14mm x 1.50	1.55	39	2.44	62	



About our knurl studs: 10.9 Grade Alloy Steel

- Cold-forge process increases durability and ensures precise measurements.
- Through-hardened heat-treated
- Other sizes available by special order

Knurl Studs



Part#	961	962	WS25902	WS18602	WS02502	WS17902	960-327E
Thread Size	7/16"-20	7/16"-20	7/16"-20	7/16"-20	7/16"-20	7/16"-20	7/16"-20
Diameter	0.480	0.575	12.05mm	12.05mm	14.25mm	14.25mm	15.90mm



Part#	967	960-138	960-364	963	960-159	960-219	960-109
Thread Size	1/2"-20	1/2"-20	1/2"-20	1/2"-20	1/2"-20	1/2"-20	1/2"-20
Diameter	N/A	0.53"	0.614"	0.615"	0.62"	0.62"	.625"



Part#	964	960-523	WS34504	WS39504	WS23404	WS29004	WS26004
Thread Size	1/2"-20	1/2"-20	1/2"-20	1/2"-20	1/2"-20	1/2"-20	1/2"-20
Diameter	0.685"	14.20mm	14.40mm	14.85mm	15.70mm	15.75mm	15.75mm

Knurl Studs



Part#	WS48004	WS44404	WS44704	WS44904	WS56904	WS36804	960-327D
Thread Size	1/2"-20	1/2"-20	1/2"-20	1/2"-20	1/2"-20	1/2"-20	1/2"-20
Diameter	15.80mm	15.80mm	15.85mm	15.85mm	15.85mm	15.90mm	15.90mm



Part#	WS37904	960-448	WS28704	WS17404	WS10304	WS44604	WS41910
Thread Size	1/2"-20	1/2"-20	1/2"-20	1/2"-20	1/2"-20	1/2"-20	9/16"-18
Diameter	15.95mm	16.90mm	17mm	17mm	17.05mm	17.30mm	15.85mm



Part#	960-327G	960-327LG	WS34710	WS52910	960-389	960-303	968
Thread Size	9/16"-18	9/16"-18	9/16"-18	9/16"-18	9/16"-18	9/16"-18	5/8"-11
Diameter	15.90mm	15.90mm	16mm	16.35mm	16.9mm	17.2mm	0.690"



Part#	969	960-327A	WS33606	960-240	960-320	960-378	WS40106
Thread Size	5/8"-11	10mm x 1.25	12mm x 1.25	12mm x 1.25	12mm x 1.25	12mm x 1.25	12mm x 1.25
Diameter	0.690"	15.90mm	12.40mm	12.90mm	12.90mm	14.35mm	14.40mm

Knurl Studs

NEW



46mm

NEW



43.70mm



46.50mm



36.00mm



34.00mm

NEW



42.80mm

NEW



54.20mm

Part#	WS40406	WS56606	960-327C	960-269	960-362	WS36007	WS32307
Thread Size	12mm x 1.25	12mm x 1.25	12mm x 1.25	12mm x 1.50	12mm x 1.50	12mm x 1.50	12mm x 1.50
Diameter	14.40mm	14.45mm	15.90mm	12.22mm	12.30mm	12.45mm	12.80mm

NEW



42.00mm

NEW



42.00mm

NEW



51.20mm

NEW



43.20mm

NEW



42.80mm



45.10mm



46.30mm

Part#	960-254	960-340	WS48607	WS51807	WS56807	WS50707	WS41007
Thread Size	12mm x 1.50	12mm x 1.50	12mm x 1.50	12mm x 1.50	12mm x 1.50	12mm x 1.50	12mm x 1.50
Diameter	12.80mm	12.80mm	12.95mm	13mm	13mm	13.05mm	13.15mm

NEW



51.20mm



40.10mm



38.50mm



45mm



37.00mm



43.70mm



37.50mm

Part#	960-365	960-266	960-253	WS46207	960-244	960-312	960-262
Thread Size	12mm x 1.50	12mm x 1.50	12mm x 1.50	12mm x 1.50	12mm x 1.50	12mm x 1.50	12mm x 1.50
Diameter	13.40mm	14.00mm	14.10mm	14.30mm	14.30mm	14.30mm	14.35mm

NEW



44.10mm



47.50mm



41.50mm



46.30mm

NEW



44mm



42.50mm



46.50mm

Part#	960-414	WS54707	960-275	960-369	WS47407	960-285	960-327B
Thread Size	12mm x 1.50	12mm x 1.50	12mm x 1.50	12mm x 1.50	12mm x 1.50	12mm x 1.50	12mm x 1.50
Diameter	14.40mm	14.45mm	14.50mm	14.70mm	14.75mm	14.94mm	15.90mm

Knurl Studs

NEW



NEW



NEW



NEW



NEW



NEW



Part#	WS39312	WS39012	WS33209	960-490	WS32909	WS32509
Thread Size	12mm x 1.75	12mm x 1.75	14mm x 1.50	14mm x 1.50	14mm x 1.50	14mm x 1.50
Diameter	14.60mm	14.80mm	15.70mm	15.70mm	15.85mm	15.85mm

NEW



NEW



NEW



NEW



NEW



NEW



Part#	960-327	960-327L	960-327S	WS32809	WS53009	WS43409
Thread Size	14mm x 1.50	14mm x 1.50	14mm x 1.50	14mm x 1.50	14mm x 1.50	14mm x 1.50
Diameter	15.90mm	15.90mm	15.90mm	15.90mm	15.90mm	15.90mm

NEW



NEW



NEW



NEW



NEW



NEW



Part#	WS50909	WS42809	960-502	WS52809	960-527	968-05
Thread Size	14mm x 1.50	14mm x 1.50	14mm x 1.50	14mm x 1.50	14mm x 1.50	14mm x 2.00
Diameter	15.95mm	15.95mm	16.02mm	16.55mm	16.50mm	0.690"

NEW



NEW



NEW



NEW



NEW



Part#	960-442	960-327F	960-327LF	WS42450	WS54250
Thread Size	14mm x 2.0	14mm x 2.00	14mm x 2.00	14mm x 2.00	14mm x 2.00
Diameter	15.50mm	15.90mm	15.90mm	15.90mm	15.90mm

Hub Centric Rings (4 Pieces per set)

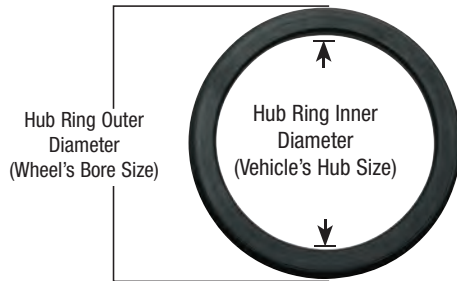

Example:
 Wheel's Bore Size (O.D.): 74.0
 Vehicle's Hub Size (I.D.): 54.06
 Part number C74-5406

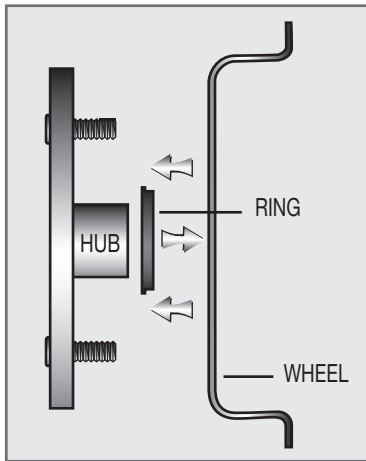

- Fills the gap between the wheel hole and hub providing true wheel-centering; prevents vibrations and enhances driving performance.
- Made of polycarbonate/nylon material which increases resistance to higher temperatures and improves durability from impact.
- Available in various combinations of bore and outer ring sizes. I.D. and O.D. sizes clearly imprinted on ring.
- 4 pc. per set.

Part No.	O.D.	I.D.
C60-5615	60.00	56.15
C66-6006	66.00	60.06
C67-5406	67.00	54.06
C67-5610	67.00	56.10
C67-5660	67.00	56.60
C67-5710	67.00	57.10
C67-5910	67.00	59.10
C67-6006	67.00	60.06
C67-6350	67.00	63.50
C67-6415	67.00	64.15
C70-5410	70.00	54.10
C70-5615	70.00	56.15
C72-5406	72.62	54.06
C72-5615	72.62	56.15
C72-5710	72.62	57.10
C72-5961	72.62	59.61
C72-6006	72.62	60.06
C72-6336	72.62	63.36
C72-6390	72.62	63.90
C72-6415	72.62	64.15
C72-6510	72.62	65.10
C72-6606	72.62	66.06
C72-6636	72.62	66.36
C72-6656	72.62	66.56
C72-6690	72.62	66.90
C72-6710	72.62	67.10
C72-7010	72.62	70.10
C72-7030	72.62	70.30
C72-7050	72.62	70.50
C72-7150	72.62	71.50
C73-5406	73.00	54.06
C73-5615	73.00	56.15
C73-5660	73.00	56.60
C73-5710	73.00	57.10

Part No.	O.D.	I.D.
C73-5910	73.00	59.10
C73-5920	73.00	59.20
C73-5961	73.00	59.61
C73-6006	73.00	60.06
C73-6340	73.00	63.40
C73-6390	73.00	63.90
C73-6415	73.00	64.15
C73-6507	73.00	65.07
C73-6606	73.00	66.06
C73-6656	73.00	66.56
C73-6690	73.00	66.90
C73-6720	73.00	67.20
C73-7010	73.00	70.10
C73-7030	73.00	70.30
C73-7050	73.00	70.50
C73-7150	73.00	71.50
C74-5406	74.00	54.06
C74-5615	74.00	56.15
C74-5710	74.00	57.10
C74-5961	74.00	59.61
C74-6006	74.00	60.06
C74-6336	74.00	63.36
C74-6390	74.00	63.90
C74-6415	74.00	64.15
C74-6507	74.00	65.07
C74-6606	74.00	66.06
C74-6656	74.00	66.56
C74-6690	74.00	66.90
C74-6706	74.00	67.06
C74-7010	74.00	70.10
C74-7030	74.00	70.30
C74-7050	74.00	70.50
C74-7150	74.00	71.50
C74-7260	74.00	72.60

Part No.	O.D.	I.D.
C78-6606	78.00	66.06
C78-6656	78.00	66.56
C78-7030	78.00	70.30
C78-7050	78.00	70.50
C78-7130	78.00	71.30
C78-7150	78.00	71.50
C78-7260	78.00	72.60
C78-7410	78.00	74.10
C83-7030	83.00	70.30
C83-7150	83.00	71.50
C83-7810	83.00	78.10
C84-7150	84.00	71.50
C87-7256	87.00	72.56
C87-7710	87.00	77.10
C87-7780	87.00	77.80
C87-7810	87.00	78.10
C106-7800	106.00	78.00
C106-7830	106.00	78.30
C106-8700	106.00	87.00
C106-9510	106.00	95.10
C108-1000	108.00	100.00
C108-1060	108.00	106.00
C108-7780	108.00	77.80
C108-7810	108.00	78.10
C108-7830	108.00	78.30
C110-1000	110.00	100.00
C110-1060	110.00	106.00
C110-7810	110.00	78.10
C125-1160	125.00	116.00
C125-1210	125.00	121.00
C130-1160	130.00	116.00
C130-1167	130.00	116.70
C130-1170	130.00	117.00
C130-1210	130.00	121.00
C130-1250	130.00	125.00

Aluminum Hub Rings (4 Pieces per set)



Part No.	O.D.	I.D.
C64-6006A	64.06	60.06
C66-5710A	66.56	57.10
C72-5710A	72.62	57.10
C72-6006A	72.62	60.06
C72-7150A	72.62	71.50

Part No.	O.D.	I.D.
C73-5615A	73.00	56.15
C73-5710A	73.00	57.10
C73-5920A	73.00	59.20
C73-6415A	73.00	64.15
C73-6710A	73.00	67.10

Part No.	O.D.	I.D.
C73-7030A	73.00	70.30
C73-7150A	73.00	71.50
C74-7256A	74.10	72.56
C108-106A	108.00	106.00

Spacers

- Made of 100% high quality cast aluminum
- Lightweight, durable, easy to install
- Quickly correct the offset of your wheels

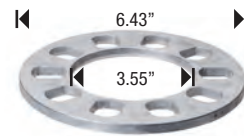
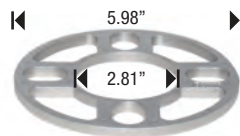
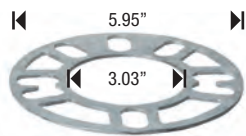

Part No.	600	601	602
Application	4 & 5 Lug	4 Lug, 4" - 4.5" B.C.	5 Lug, 4.5"-5" B.C.
Thickness	3mm	5/16"	5/16"

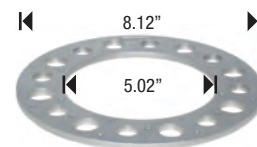
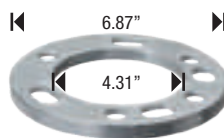
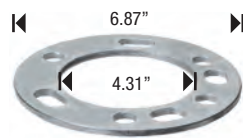
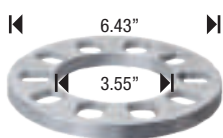

Part No.	602T	603	603T	604
Application	5 Lug, 4.5"-5" B.C.	5 & 6 Lug, 5.5" & 135mm B.C.	5 & 6 Lug, 5.5" & 135mm B.C.	8 Lug, 6.5" & 170mm B.C.
Thickness	1/2"	1/4"	1/2"	1/4"

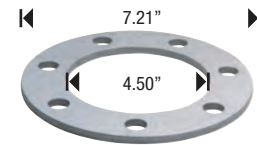
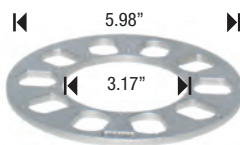
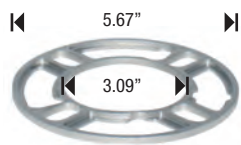
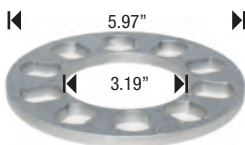

Part No.	605	606	607	628
Application	5 Lug, 100mm B.C.	4 & 5 Lug	5 Lug, 4"-4.75" BC	7 Lug, 150mm B.C.
Thickness	5/16"	5mm	5mm	1/4"

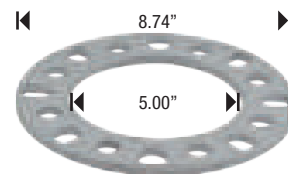
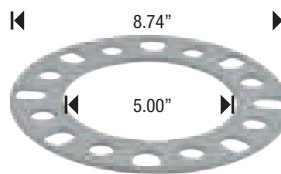
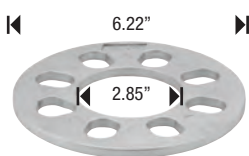
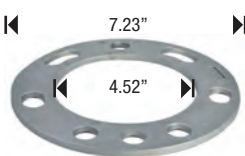

Part No.	629	630	631	631T
Application	5 & 7 lug, 150mm B.C.	4 lug, 4"-4.5" B.C.	8 Lug, 6.5", 170mm & 180mm B.C.	8 Lug, 6.5", 170mm & 180mm B.C.
Thickness	1/4"	1/4"	1/4"	1/2"

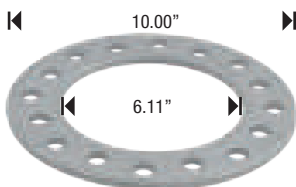
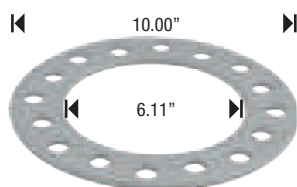

Part No.	632	632T	633	633T
Application	8 Lug, 200mm & 210mm B.C.	8 Lug, 200mm & 210mm B.C.	6 Lug, 114.3mm(4.5")/120mm/127mm(5")/132mm B.C.	6 Lug, 114.3mm(4.5")/120mm/127mm(5")/132mm B.C.
Thickness	1/4"	1/2"	1/4"	1/2"

Hub-Centric Spacers

- Made from forged heat-treated 6061-T6 aluminum

5 Lug Mercedes-Benz Center Bore 66.56mm

Part No.	Application	Thickness	Shoulder
C112-12	5 x 112mm	12mm	Yes
C112-15	5 x 112mm	15mm	Yes
C112-17	5 x 112mm	17mm	Yes
C112-20	5 x 112mm	20mm	Yes
Add BK for Black			

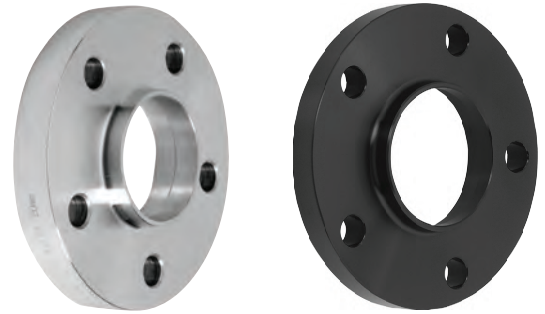

5 Lug BMW Center Bore 72.56mm

Part No.	Application	Thickness	Shoulder
C120-5N	5 x 120mm	5mm	No Shoulder
C120-10	5 x 120mm	10mm	Yes
C120-12	5 x 120mm	12mm	Yes
C120-15	5 x 120mm	15mm	Yes
C120-17	5 x 120mm	17mm	Yes
C120-20	5 x 120mm	20mm	Yes
Add BK for Black			



4 Lug Center Bore 57.10mm

Part No.	Application	Thickness	Shoulder
C4100-5N	4 x 100mm	5mm	No Shoulder
C4100-8N	4 x 100mm	8mm	No Shoulder
C4100-10	4 x 100mm	10mm	Yes
C4100-12	4 x 100mm	12mm	Yes
C4100-15	4 x 100mm	15mm	Yes
C4100-20	4 x 100mm	20mm	Yes
Add BK for Black			



5 Lug Center Bore 57.10mm

Part No.	Application	Thickness	Shoulder
C100/112-3	5 x 100 & 5 x 112	3mm	No Shoulder
C100/112-5	5 x 100 & 5 x 112	5mm	No Shoulder
C100/112-8	5 x 100 & 5 x 112	8mm	No Shoulder
C100/112-10	5 x 100 & 5 x 112	10mm	No Shoulder
C100/112-15	5 x 100 & 5 x 112	15mm	No Shoulder
C5100/5112-10	5 x 100 & 5 x 112	10mm	Yes
C5100/5112-15	5 x 100 & 5 x 112	15mm	Yes
C5100/5112-20	5 x 100 & 5 x 112	20mm	Yes
C5100/5112-25	5 x 100 & 5 x 112	25mm	Yes

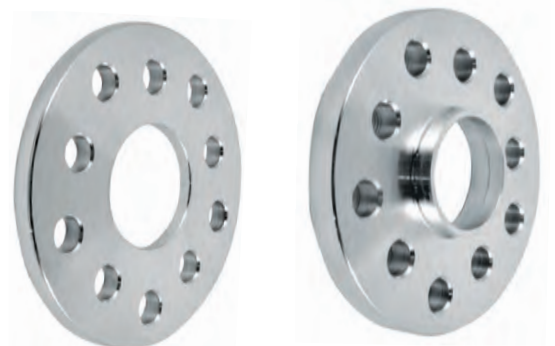

Hub Centric Spacers

5 Lug Center Bore 66.56mm

Part No.	Application	Thickness	Shoulder
CA100/112-3	5 x 100 & 5 x 112	3mm	No Shoulder
CA100/112-5	5 x 100 & 5 x 112	5mm	No Shoulder

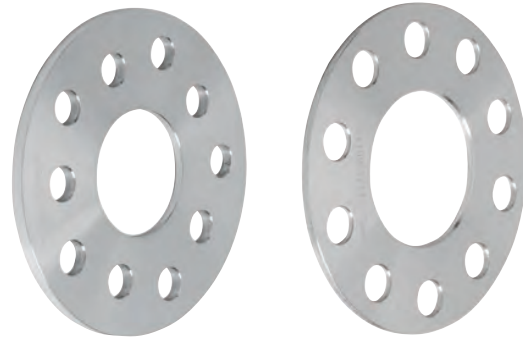

5 Lug Center Bore 65.00mm

Part No.	Application	Thickness	Shoulder
C108/110-3	5 x 108 & 5 x 110	3mm	No Shoulder

5 Lug Center Bore 67.10mm

Part No.	Application	Thickness	Shoulder
C108/114-3	5 x 108 & 5 x 114.3	3mm	No Shoulder
C108/114-5	5 x 108 & 5 x 114.3	5mm	No Shoulder



5 Lug Center Bore 66.56mm

Part No.	Application	Thickness	Shoulder
C112-5N	5 x 112mm	5mm	No Shoulder
C112-10N	5 x 112mm	10mm	No Shoulder



5 Lug Center Bore 71.60mm

Part No.	Application	Thickness	Shoulder
C130-5N	5 x 130mm	5mm	No Shoulder
C130-12	5 x 130mm	12mm	Yes
C130-15	5 x 130mm	15mm	Yes
C130-20	5 x 130mm	20mm	Yes

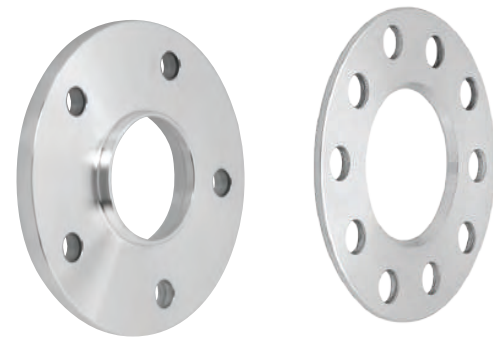

5 Lug Center Bore 71.50mm

Part No.	Application	Thickness	Shoulder
C114/120-5	5 x 114 & 5 x 120	5mm	No Shoulder
C114/120-8	5 x 114 & 5 x 120	8mm	No Shoulder

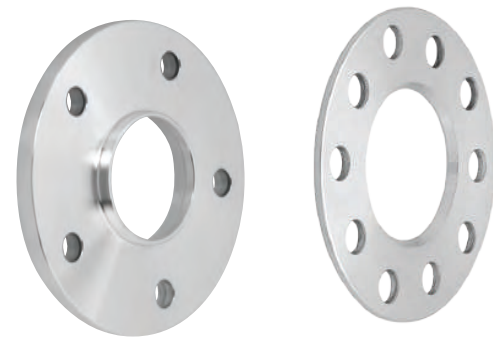

5 Lug Center Bore 74.10mm

Part No.	Application	Thickness	Shoulder
C120/74-5N	5 x 120mm	5mm	No Shoulder
C120/74-15	5 x 120mm	15mm	Yes
C120/74-20	5 x 120mm	20mm	Yes

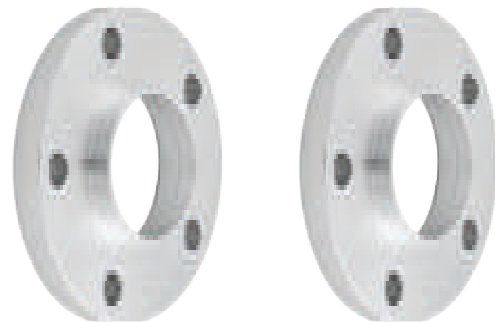

5 Lug Center Bore Conversion, 74.10mm to 72.56mm

Part No.	Application	Thickness	Shoulder
C120/74-72-15	5 x 120mm	15mm	Yes
C120/74-72-20	5 x 120mm	20mm	Yes

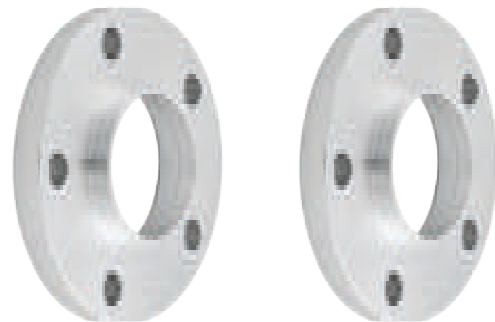

Wheel Adapters

Metric Converter:

4.25" = 108mm 5.00" = 127mm
 4.50" = 114.3mm 5.50" = 139.7mm
 4.75" = 120.7mm 6.50" = 165mm

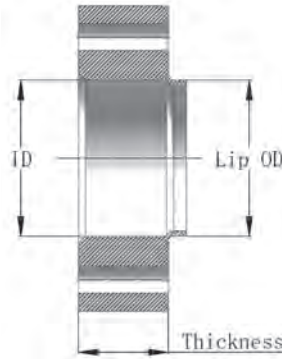











	Part #	Vehicle	Wheel	Thickness	ID	Hub Centric & Lip OD	Stud Thread size	Dual-Drilled	Finish	2 Piece
4 LUG & ATV	WA4100/4450-4425A	4x100mm/4X4.50"	4x4.25"	1"	74mm	-	12mm 1.50	X		
	WA4100-4100B	4x100mm	4x100mm	1.25"	60mm	-	12mm 1.50			
	WA4110-4110A	4x110mm	4x110mm	1"	84mm	-	10mm 1.25			
	WA4110-4110C	4x110mm	4x110mm	1.5"	84mm	-	10mm 1.25			
	WA4110-4110E	4x110mm	4x110mm	2"	84mm	-	10mm 1.25			
	WA4110-4110G	4x110mm	4x110mm	2.5"	84mm	-	10mm 1.25			
	WA4136-4136A	4x136mm	4x136mm	1"	117.5mm	-	10mm 1.25			
	WA4136-4136C	4x136mm	4x136mm	1.5"	117.5mm	-	10mm 1.25			
	WA4136-4136C12	4x136mm	4x136mm	1.5"	110mm	-	12mm 1.50			
	WA4136-4136E	4x136mm	4x136mm	2"	117.5mm	-	10mm 1.25			
	WA4136-4136E12	4x136mm	4x136mm	2"	110mm	-	12mm 1.50			
	WA4136-4136G	4x136mm	4x136mm	2.5"	117.5mm	-	10mm 1.25			
	WA4156-4156A	4x156mm	4x156mm	1"	131mm	-	3/8"-24			
	WA4156-4156B12	4x156mm	4x156mm	1.25"	131mm	-	12mm 1.50			
	WA4156-4156C	4x156mm	4x156mm	1.5"	131mm	-	3/8"-24			
	WA4156-4156C12	4x156mm	4x156mm	1.5"	131mm	-	12mm 1.50			
	WA4156-4156E	4x156mm	4x156mm	2"	131mm	-	3/8"-24			
	WA4156-4156G	4x156mm	4x156mm	2.5"	131mm	-	3/8"-24			
	WA4400-4400C	4x4.00"	4x4.00"	1.5"	77.8mm	-	1/2"-20			
	WA4425/4100-4450A	4x4.25"/4x100mm	4x4.50"	1"	74mm	-	12mm 1.50	X		
WA4425-4100B	4x4.25"/4x100mm	4x100mm	1.25"	74mm	-	12mm 1.50				
WA4450-4100B	4x4.50"	4x100mm	1.25"	71mm	-	12mm 1.50				
WA4450-4450E	4x4.50"	4x4.50"	2"	84mm	-	10mm 1.25				
5 LUG	WA5100/5425-5450B	5x100mm/5x4.25"	5x4.50"	1.25"	74mm	-	12mm 1.50	X		
	WA5100/5425-5475B	5x100mm/5x4.25"	5x4.75"	1.25"	74mm	-	12mm 1.50	X		
	WA5100/5450-15BK	5x100mm	5x4.50"	15mm	56.1mm	-	12mm 1.25	X	Black	
	WA5100/5450-5100B	5x100mm/5x4.50"	5x100mm	1.25"	74.1mm	-	12mm 1.50	X		
	WA5100-5450A	5X100mm	5x4.50"	1"	64mm	-	12mm 1.50			
	WA5105/5110-5450A	5x105mm/5x110mm	5x4.50"	1"	74.1mm	-	12mm 1.50	X		
	WA5110-5110A	5x110mm	5x110mm	1"	65.1mm	-	12mm 1.50			
	WA5112/5130-5450B	5x112mm/5x130mm	5x4.50"	1.25"	84.1mm	-	12mm 1.50	X		
	WA5112/5130-5475B	5x112mm/5x130mm	5x4.75"	1.25"	84.1mm	-	12mm 1.50	X		
	WA5112-5112AH	5x112mm	5x112mm	1"	66.56mm	66.56mm	12mm 1.50			
	WA5112-5112BH	5x112mm	5x112mm	1.25"	66.56mm	66.56mm	12mm 1.50			
	WA5115-5115AH	5x115mm	5x115mm	1"	71.5mm	71.5mm	14mm 1.50			
	WA5115-5115B	5x115mm	5x115mm	1.25"	73.1mm	-	14mm 1.50			
	WA5115-5115BH	5x115mm	5x115mm	1.25"	71.5mm	71.5mm	14mm 1.50			
	WA5115-5115E	5x115mm	5x115mm	2"	73.1mm	-	14mm 1.50			
	WA5115-5450B	5x115mm	5x4.5"	1.25"	71.5mm	-	14mm 1.50			
WA5115-5475B	5x115mm	5x4.75"	1.25"	71.5mm	-	14mm 1.50				

Wheel Adapters

DISCLAIMER:

THE USE OF WHEEL ADAPTERS IS AT YOUR OWN RISK
AND YOU ASSUME ALL LIABILITY FOR SUITABILITY, SIZING, FIT, INSTALLATION AND USE.
IMPROPER INSTALLATION CAN RESULT IN ACCIDENT AND/OR INJURY.
DO NOT ATTEMPT INSTALLATION UNLESS YOU ARE A QUALIFIED MECHANIC.

	Part #	Vehicle	Wheel	Thickness	ID	Hub Centric & Lip OD	Stud Thread size	Dual-Drilled	Finish	2 Piece
5 LUG	WA5135/5500-5135C	5x135mm/5x5.00"	5x135mm	1.5"	87.1mm	-	12mm 1.50	X		
	WA5135/5500-5450B	5x135mm/5x5.00"	5x4.50"	1.25"	87.1mm	-	12mm 1.50	X		
	WA5135/5500-5450C	5x135mm/5x5.00"	5x4.50"	1.5"	87.1mm	-	12mm 1.50	X		
	WA5135/5500-5475B	5x135mm/5x5.00"	5x4.75"	1.25"	87.1mm	-	12mm 1.50	X		
	WA5135/5500-5475C	5x135mm/5x5.00"	5x4.75"	1.5"	87.1mm	-	12mm 1.50	X		
	WA5135/5500-5500C	5x135mm/5x5.00"	5x5.00"	1.5"	87.1mm	-	12mm 1.50	X		
	WA5135/5500-5550C	5x135mm/5x5.00"	5x5.50"	1.5"	87.1mm	-	12mm 1.50	X		
	WA5135/5500-6550E	5x135mm/5x5.00"	6x5.50"	2"	87.1mm	-	14mm 1.50	X		YES
	WA5135/5500-8650E	5x135mm/5x5.00"	8x6.50"	2"	87.1mm	-	14mm 1.50	X		YES
	WA5135/5550-5135B	5x135mm/5x5.50"	5x135mm	1.25"	87.1mm	-	12mm 1.50	X		
	WA5135/5550-5135E142	5x135mm/5x5.50"	5x135mm	2"	87.1mm	-	14mm 2.00	X		
	WA5135/5550-6550E	5x135mm/5x5.50"	6x5.50"	2"	87.1mm	-	14mm 1.50	X		YES
	WA5135-5135EH	5x135mm	5x135mm	2"	87.1mm	87.1mm	14mm 2.00			
	WA5135-5450C	5x135mm	5x4.50"	1.5"	87.1mm	-	12mm 1.50			
	WA5135-5475B	5x135mm	5x4.75"	1.25"	87.1mm	-	14mm 2.00			
	WA5135-5500C	5x135mm	5x5.00"	1.5"	87.1mm	-	14mm 2.00			
	WA5135-5550C	5x135mm	5x5.50"	1.5"	87.1mm	-	14mm 2.00			
	WA5135-6135E	5x135mm	6x135mm	2"	87.1mm	-	12mm 1.50			YES
	WA5150-5150CH	5x150mm	5x150mm	1.5"	110mm	110mm	14mm 1.50			
	WA5150-5150CHBK	5x150mm	5x150mm	1.5"	110mm	110mm	14mm 1.50		BLACK	
	WA5150-5150EH	5x150mm	5x150mm	2"	110mm	110mm	14mm 1.50			
	WA5150-5150EHBK	5x150mm	5x150mm	2"	110mm	110mm	14mm 1.50		BLACK	
	WA5150-6550EH	5x150mm	6x5.50"	2"	110mm	78.1mm	14mm 1.50			YES
	WA5425/5450-5475B	5x4.25" & 5x4.50"	5x4.75"	1.25"	78.1mm	-	12mm 1.50	X		
	WA5425-5450B	5x4.25"	5x4.50"	1.25"	73.1mm	-	12mm 1.50			
	WA5450/5475-5110B	5x4.50"/5x4.75"	5x110mm	1.25"	74.1mm	-	12mm 1.50	X		
	WA5450/5475-5112B	5x4.50"/5x4.75"	5x112mm	1.25"	74.1mm	-	12mm 1.50	X		
	WA5450/5475-5115B	5x4.50"/5x4.75"	5x115mm	1.25"	74.1mm	-	12mm 1.50	X		
	WA5450/5475-5135B	5x4.50"/5x4.75"	5x135mm	1.25"	74.1mm	-	12mm 1.50	X		
	WA5450/5475-5425B	5x4.50" & 5x4.75"	5x4.25"	1.25"	74.1mm	-	12mm 1.50	X		
	WA5450/5475-5450A	5x4.50"/5x4.75"	5x4.50"	1"	78.1mm	-	12mm 1.50	X		
	WA5450/5475-5450B	5x4.50"/5x4.75"	5x4.50"	1.25"	74.1mm	-	12mm 1.50	X		
	WA5450/5475-5450BBK	5x4.50"/5x4.75"	5x4.50"	1.25"	74.1mm	-	12mm 1.50	X	BLACK	
	WA5450/5475-5450E	5x4.50"/5x4.75"	5x4.50"	2"	78.1mm	-	12mm 1.50	X		
	WA5450/5475-5475B	5x4.50"/5x4.75"	5x4.75"	1.25"	74.1mm	-	12mm 1.50	X		
	WA5450/5475-5475BBK	5x4.50"/5x4.75"	5x4.75"	1.25"	74.1mm	-	12mm 1.50	X	BLACK	
	WA5450/5475-5475E	5x4.50"/5x4.75"	5x4.75"	2"	78.1mm	-	12mm 1.50	X		
	WA5450/5475-5500B	5x4.50"/5x4.75"	5x5.00"	1.25"	74.1mm	-	12mm 1.50	X		
	WA5450/5475-5550B	5x4.50"/5x4.75"	5x5.50"	1.25"	74.1mm	-	12mm 1.50	X		
	WA5450-5450A	5x4.50"	5x4.50"	1"	74.1mm	-	12mm 1.50			
	WA5450-5450A1/2	5x4.50"	5x4.50"	1"	74.1mm	-	1/2"-20			
	WA5450-5450ABK	5x4.50"	5x4.50"	1"	74.1mm	-	12mm 1.50		BLACK	

Wheel Adapters

- Our billet wheel adapters are CNC machined
- Made from forged heat-treated 6061-T6 aluminum
- Pressed-In studs included
- Open-End lug nuts included



Regular



Black Dual-Drilled

	Part #	Vehicle	Wheel	Thickness	ID	Hub Centric & Lip OD	Stud Thread size	Dual-Drilled	Finish	2 Piece
5 LUG	WA5450-5450AH1/2	5x4.50"	5x4.50"	1"	70.5mm	70.5mm	1/2"-20			
	WA5450-5450AH14	5x4.50"	5x4.50"	1"	70.5mm	70.5mm	14mm 1.50			
	WA5450-5450B	5x4.50"	5x4.50"	1.25"	74.1mm	-	12mm 1.50			
	WA5450-5450B1/2	5x4.50"	5x4.50"	1.25"	74.1mm	-	1/2"-20			
	WA5450-5450BBK	5x4.50"	5x4.50"	1.25"	74.1mm	-	12mm 1.50		BLACK	
	WA5450-5450C	5x4.50"	5x4.50"	1.5"	74.1mm	-	12mm 1.50			
	WA5450-5450C1/2	5x4.50"	5x4.50"	1.5"	74.1mm	-	1/2"-20			
	WA5450-5450CBK	5x4.50"	5x4.50"	1.5"	74.1mm	-	12mm 1.50		BLACK	
	WA5450-5450CH	5x4.50"	5x4.50"	1.5"	71.5mm	71.5mm	1/2"-20			
	WA5450-5450CH1/2	5x4.50"	5x4.50"	1.5"	70.5mm	70.5mm	1/2"-20			
	WA5450-5450E	5x4.50"	5x4.50"	2"	74.1mm	-	12mm 1.50			
	WA5450-5450E1/2	5x4.50"	5x4.50"	2"	74.1mm	-	1/2"-20			
	WA5450-5450EH	5x4.50"	5x4.50"	2"	71.5mm	71.5mm	1/2"-20			
	WA5450-5450V15	5x4.50"	5x4.50"	15mm	60.1/64.1mm	60.1/64.1mm	12mm 1.50			
Note: Includes C64-6010A aluminum hub ring, provides flexibility to adjust ID and OD between 64.06 to 60.06										
WA5450-5450V20	5x4.50"	5x4.50"	20mm	60.1/64.1mm	60.1/64.1mm	12mm 1.50				
Note: Includes C64-6010A aluminum hub ring, provides flexibility to adjust ID and OD between 64.06 to 60.06										
	WA5450-5475A	5x4.50"	5x4.75"	1"	74.1mm	-	12mm 1.50			
	WA5450-5475AH1/2	5x4.50"	5x4.75"	1"	74.1mm	74.1mm	1/2"-20			
	WA5450-5475B	5x4.50"	5x4.75"	1.25"	74.1mm	-	12mm 1.50			
	WA5450-5500B	5x4.50"	5x5.00"	1.25"	74.1mm	-	12mm 1.50			
	WA5450-5500B1/2	5x4.50"	5x5.00"	1.25"	71.5mm	-	1/2"-20			
	WA5450-5500BH1/2	5x4.50"	5x5.00"	1.25"	71.5mm	71.5mm	1/2"-20			
	WA5450-5500E1/2	5x4.50"	5x5.00"	2"	71.5mm	-	1/2"-20			
	WA5450-5500EH1/2	5x4.50"	5x5.00"	2"	71.5mm	71.5mm	1/2"-20			
	WA5450-5550A1/2	5x4.50"	5x5.50"	1"	71.5mm	-	1/2"-20			
	WA5450-6550E	5x4.50"	6x5.50"	2"	74.1mm	74.1mm	12mm 1.50			YES
	WA5475/5500-5112B	5x4.75"/5x5.00"	5x112mm	1.25	78.1mm	-	12mm 1.50	X		
	WA5475/5500-5500B	5x4.75"/5x5.00"	5x5.00"	1.25"	78.1mm	-	12mm 1.50	X		
	WA5475/5500-5500C	5x4.75"/5x5.00"	5x5.00"	1.5"	78.1mm	-	12mm 1.50	X		
	WA5475-5450B	5x4.75"	5x4.50"	1.25"	74.1mm	-	12mm 1.50			
	WA5475-5475A	5x4.75"	5x4.75"	1"	74.1mm	-	12mm 1.50			
	WA5475-5475AH	5x4.75"	5x4.75"	1"	71.5mm	71.5mm	12mm 1.50			
	WA5475-5475B	5x4.75"	5x4.75"	1.25"	74.1mm	-	12mm 1.50			
	WA5475-5475C	5x4.75"	5x4.75"	1.5"	74.1mm	-	12mm 1.50			
	WA5475-5475CH	5x4.75"	5x4.75"	1.5"	70.5mm	70.5mm	12mm 1.50			
	WA5475-5475E	5x4.75"	5x4.75"	2"	74.1mm	-	12mm 1.50			
	WA5475-5500B	5x4.75"	5x5.00"	1.25"	74.1mm	-	12mm 1.50			
	WA5475-6550E	5x4.75"	6x5.50"	2"	74.1mm	74.1mm	12mm 1.50			YES
	WA5500/5550-5135B	5x5.00"/5x5.50"	5x135mm	1.25"	87.1mm	-	12mm 1.50	X		

Wheel Adapters



Hub-Centric



Dual-Drilled



8 Lug Black

	Part #	Vehicle	Wheel	Thickness	ID	Hub Centric & Lip OD	Stud Thread size	Dual-Drilled	Finish	2 Piece
5 LUG	WA5500/5550-5135C	5x5.00"/5x5.50"	5x135mm	1.5"	87.1mm	-	1/2"-20	X		
	WA5500/5550-5150C	5x5.00"/5x5.50"	5x150mm	1.5"	87.1mm	-	14mm 1.50	X		
	WA5500/5550-5450B	5x5.00"/5x5.50"	5x4.50"	1.25"	87.1mm	-	12mm 1.50	X		
	WA5500/5550-5450C	5x5.00"/5x5.50"	5x4.50"	1.5"	87.1mm	-	12mm 1.50	X		
	WA5500/5550-5475B	5x5.00"/5x5.50"	5x4.75"	1.25"	87.1mm	-	12mm 1.50	X		
	WA5500/5550-5475C	5x5.00"/5x5.50"	5x4.75"	1.5"	87.1mm	-	12mm 1.50	X		
	WA5500/5550-5500B	5x5.00"/5x5.50"	5x5.00"	1.25"	87.1mm	-	12mm 1.50	X		
	WA5500/5550-5550C	5x5.00"/5x5.50"	5x5.50"	1.5"	87.1mm	-	1/2"-20	X		
	WA5500-5450B	5x5.00"	5x4.50"	1.25"	78.1mm	-	12mm 1.50			
	WA5500-5450B1/2	5x5.00"	5x4.50"	1.25"	78.1mm	-	1/2"-20			
	WA5500-5475B	5x5.00"	5x4.75"	1.25"	78.1mm	-	12mm 1.50			
	WA5500-5500-20	5x5.00"	5x5.00"	20mm	78.1mm	-	12mm 1.50			
	WA5500-5500A1/2	5x5.00"	5x5.00"	1"	78.1mm	-	1/2"-20			
	WA5500-5500B	5x5.00"	5x5.00"	1.25"	78.1mm	-	12mm 1.50			
	WA5500-5500BH	5x5.00"	5x5.00"	1.25"	71.5mm	71.5mm	1/2"-20			
	WA5500-5500BH14	5x5.00"	5x5.00"	1.25"	71.5mm	71.5mm	14mm 1.50			
	WA5500-5500C1/2	5x5.00"	5x5.00"	1.5"	78.1mm	-	1/2"-20			
	WA5500-5500CH	5x5.00"	5x5.00"	1.5"	71.5mm	71.5mm	1/2"-20			
	WA5500-5500CH14	5x5.00"	5x5.00"	1.5"	71.5mm	71.5mm	14mm 1.50			
	WA5500-5500E1/2	5x5.00"	5x5.00"	2"	78.1mm	-	1/2"-20			
	WA5500-5500EH	5x5.00"	5x5.00"	2"	71.5mm	71.5mm	1/2"-20			
	WA5500-5500EH14	5x5.00"	5x5.00"	2"	71.5mm	71.5mm	14mm 1.50			
	WA5500-6550E	5x5.00"	6x5.50"	2"	78.1mm	78.1mm	12mm 1.50			YES
	WA5550/5135-5550B	5x5.50"/5x135mm	5x5.50"	1.25"	87.1mm	-	12mm 1.50	X		
	WA5550-5450B	5x5.50"	5x4.50"	1.25"	78.1mm	-	9/16"-18			
	WA5550-5450C	5x5.50"	5x4.50"	1.5"	87.1mm	-	12mm 1.50			
	WA5550-5550A1/2	5x5.50"	5x5.50"	1"	87.1mm	-	1/2"-20			
	WA5550-5550B	5x5.50"	5x5.50"	1.25"	87.1mm	-	1/2"-20			
	WA5550-5550B14	5x5.50"	5x5.50"	1.25"	87.1mm	-	14mm 1.50			
	WA5550-5550C	5x5.50"	5x5.50"	1.5"	108mm	-	12mm 1.25			
	WA5550-5550C1/2	5x5.50"	5x5.50"	1.5"	108mm	-	1/2"-20			
	WA5550-5550C14	5x5.50"	5x5.50"	1.5"	77.8mm	-	14mm 1.50			
	WA5550-5550E	5x5.50"	5x5.50"	2"	108mm	-	12mm 1.25			
	WA5550-5550E1/2	5x5.50"	5x5.50"	2"	108mm	-	1/2"-20			
	WA5550-5550E14	5x5.50"	5x5.50"	2"	77.8mm	-	14mm 1.50			
	WA5550-6135E	5x5.50"	6x135mm	2"	108mm	108mm	1/2"-20			YES
	WA5550-6550E	5x5.50"	6x5.50"	2"	108mm	108mm	1/2"-20			YES
6 LUG	WA6120-6120B	6x120mm	6x120mm	1.25"	67.1mm	-	14mm 1.50			
		WA6120-6120CH14	6x120mm	6x120mm	1.5"	66.9mm	66.9mm	14mm 1.50		
	WA6135/6500-6135C	6x135mm/6x5.00"	6x135mm	1.5"	87.1mm	-	12mm 1.50	X		

Wheel Adapters



Regular

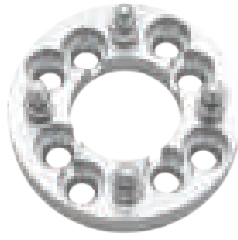

4 Lug





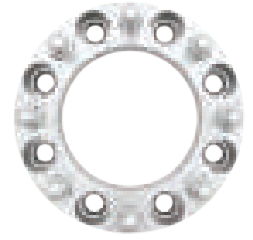



















6 Lug



8 Lug

	Part #	Vehicle	Wheel	Thickness	ID	Hub Centric & Lip OD	Stud Thread size	Dual-Drilled	Finish	2 Piece
6 LUG	WA6135/6500-6550B14	6x135mm/6x5.00"	6x5.50"	1.25"	87.1mm	-	14mm 1.50	X		
	WA6135/6550-6500C	6x135mm/6X5.50"	6X5.00"	1.5"	87.1mm	-	12mm 1.50	X		
	WA6135/6550-6550C14	6x135mm/6x5.50"	6x5.50"	1.5"	108mm	-	14mm 1.50	X		
	WA6135/6550-6550E14	6x135mm/6x5.50"	6x5.50"	2"	108mm	-	14mm 1.50	X		
	WA6135-6135C	6x135mm	6x135mm	1.5"	87.1mm	-	14mm 2.00			
	WA6135-6135CBK	6x135mm	6x135mm	1.5"	87.1mm	-	14mm 2.00		BLACK	
	WA6135-6135CH	6x135mm	6x135mm	1.5"	87.1mm	87.1mm	14mm 2.00			
	WA6135-6135CH14	6x135mm	6x135mm	1.5"	87.1mm	87.1mm	14mm 1.50			
	WA6135-6135EH	6x135mm	6x135mm	2"	87.1mm	87.1mm	14mm 2.00			
	WA6135-6135EH14	6x135mm	6x135mm	2"	87.1mm	87.1mm	14mm 1.50			
	WA6135-6550C	6x135mm	6x5.50"	1.5"	108mm	-	14mm 2.00			
	WA6135-6550C14	6x135mm	6x5.50"	1.5"	108mm	-	14mm 1.50			
	WA6135-6550CH14	6x135mm	6x5.50"	1.5"	87.1mm	78.1mm	14mm 1.50			
	WA6450-6450BH25	6x4.50"	6x4.50"	1.25"	66.1mm	66.1mm	12mm 1.25			
	WA6450-6450CH25	6x4.50"	6x4.50"	1.5"	66.1mm	66.1mm	12mm 1.25			
	WA6450-6450EH1/2	6x4.50"	6x4.50"	2"	71.5mm	71.5mm	1/2"-20	X		
	WA6450-6450EH25	6x4.50"	6x4.50"	2"	66.1mm	66.1mm	12mm 1.25			
	WA6450-6550B1/2	6x4.50"	6x5.50"	1.25"	78.1mm	-	1/2"-20			
	WA6500-6500BH	6x5.00"	6x5.00"	1.25"	78.1mm	78.1mm	12mm 1.50			
	WA6500-6500C	6x5.00"	6x5.00"	1.5"	78.1mm	-	12mm 1.50			
	WA6500-6550B	6x5.00"	6x5.50"	1.25"	78.1mm	-	12mm 1.50			
	WA6550/6135-5150E14	6x5.50"/6x135mm	5x150mm	2"	87.1mm	-	14mm 1.50	X		YES
	WA6550/6135-5450E	6x5.50"/6x135mm	5x4.50"	2"	87.1mm	-	1/2"-20	X		YES
	WA6550/6135-5500E14	6x5.50"/6x135mm	5x5.00"	2"	87.1mm	-	14mm 1.50	X		YES
	WA6550/6135-5550E14	6x5.50"/6x135mm	5X5.50"	2"	87.1mm	-	14mm 1.50	X		YES
	WA6550/6135-6135B	6x5.50"/6x135mm	6x135mm	1.25"	108mm	-	14mm 1.50	X		
	WA6550/6135-6550B	6x5.50"/6x135mm	6x5.50"	1.25"	108mm	-	14mm 1.50	X		
	WA6550/6135-8170E14	6x5.50"/6x135mm	8x170mm	2"	87.1mm	-	14mm 1.50	X		YES
	WA6550/6135-8180E14	6x5.50"/6x135mm	8x180mm	2"	87.1mm	-	14mm 1.50	X		YES
	WA6550/6135-8650E14	6x5.50"/6x135mm	8x6.50"	2"	87.1mm	-	14mm 1.50	X		YES
	WA6550-5150E	6x5.50"	5x150mm	2"	108mm	-	12mm 1.50			YES
	WA6550-5450E	6x5.50"	5x4.50"	2"	108mm	-	12mm 1.50			YES
	WA6550-5450E14	6x5.50"	5x4.50"	2"	108mm	-	14mm 1.50			YES
	WA6550-5475E14	6x5.50"	5x4.75"	2"	108mm	-	14mm 1.50			YES
	WA6550-6135C142	6x5.50"	6x135mm	1.5"	78.1mm	-	14mm 2.00			
	WA6550-6135CH14	6x5.50"	6x135mm	1.5"	78.1mm	87.1	14mm 1.50			
	WA6550-6550A14	6x5.50"	6x5.50"	1"	108mm	-	14mm 1.50			
	WA6550-6550A25	6x5.50"	6x5.50"	1"	108mm	-	12mm 1.25			
	WA6550-6550B	6X5.50"	6x5.50"	1.25"	108mm	-	12mm 1.50			
	WA6550-6550B14	6X5.50"	6X5.50"	1.25"	108mm	-	14mm 1.50			

Wheel Adapters

	Part #	Vehicle	Wheel	Thickness	ID	Hub Centric & Lip OD	Stud Thread size	Dual-Drilled	Finish	2 Piece
6 LUG	WA6550-6550B14BK	6x5.50"	6x5.50"	1.25"	108mm	-	14mm 1.50		BLACK	
	WA6550-6550B25	6x5.50"	6x5.50"	1.25"	108mm	-	12mm 1.25			
	WA6550-6550BH	6x5.50"	6x5.50"	1.25"	106mm	106mm	12mm 1.50			
	WA6550-6550BH14	6x5.50"	6x5.50"	1.25"	78.1mm	78.1mm	14mm 1.50			
	WA6550-6550C	6x5.50"	6x5.50"	1.5"	108mm	-	12mm 1.50			
	WA6550-6550C25	6x5.50"	6x5.50"	1.5"	108mm	-	12mm 1.25			
	WA6550-6550CBK	6x5.50"	6x5.50"	1.5"	108mm	-	12mm 1.50		BLACK	
	WA6550-6550CH	6x5.50"	6x5.50"	1.5"	106mm	106mm	12mm 1.50			
	WA6550-6550CH14	6x5.50"	6x5.50"	1.5"	78.1mm	78.1mm	14mm 1.50			
	WA6550-6550CH14BK	6x5.50"	6x5.50"	1.5"	78.1mm	78.1mm	14mm 1.50		BLACK	
	WA6550-6550E	6x5.50"	6x5.50"	2"	108mm	-	12mm 1.50			
	WA6550-6550E14	6x5.50"	6x5.50"	2"	108mm	-	14mm 1.50			
	WA6550-6550E25	6x5.50"	6x5.50"	2"	108mm	-	12mm 1.25			
	WA6550-6550EH	6x5.50"	6x5.50"	2"	106mm	106mm	12mm 1.50			
	WA6550-6550EH14	6x5.50"	6x5.50"	2"	78.1mm	78.1mm	14mm 1.50			
	WA6550-6550EH14BK	6x5.50"	6x5.50"	2"	78.1mm	78.1mm	14mm 1.50		BLACK	
	WA6550-6550I	6x5.50"	6x5.50"	3"	108mm	-	12mm 1.50			
	WA6550-6550I14	6x5.50"	6x5.50"	3"	108mm	-	14mm 1.50			
	WA6550-8170E	6x5.50"	8x170mm	2"	108mm	-	14mm 1.50			YES
	WA6550-8650E	6x5.50"	8x6.50"	2"	108mm	-	14mm 1.50			YES
8 LUG 	WA8170-8170C14	8x170mm	8x170mm	1.5"	125mm	-	14mm 1.50			
	WA8170-8170E	8x170mm	8x170mm	2"	125mm	-	14mm 2.00			
	WA8170-8170E14	8x170mm	8x170mm	2"	125mm	-	14mm 1.50			
	WA8170-8170E14BK	8x170mm	8x170mm	2"	125mm	-	14mm 1.50		BLACK	
	WA8170-8170EBK	8x170mm	8x170mm	2"	125mm	-	14mm 2.00		BLACK	
	WA8170-8170EH	8x170mm	8x170mm	2"	125mm	125mm	14mm 2.00			
	WA8170-8170EH14	8x170mm	8x170mm	2"	125mm	125mm	14mm 1.50			
	WA8170-8200E14	8x170mm	8x200mm	2"	125.6mm	-	14mm 1.50			
	WA8170-8650E14	8x170mm	8x6.50"	2"	130mm	-	14mm 1.50			
	WA8180-6550E14	8x180mm	6x5.50"	2"	124.3mm	-	14mm 1.50			YES
	WA8180-8180E	8x180mm	8x180mm	2"	124.3mm	-	14mm 1.50			
	WA8180-8180EBK	8x180mm	8x180mm	2"	124.3mm	-	14mm 1.50		BLACK	
	WA8200-8200E	8x200mm	8x200mm	2"	146mm	-	14mm 1.50			
	WA8200-8200EH	8x200mm	8x200mm	2"	142mm	142mm	14mm 1.50			
	WA8210-8210E	8x210mm	8x210mm	2"	155mm	-	14mm 1.50			
	WA8210-8210EHBK	8x210mm	8x210mm	2"	154.2mm	154.2mm	14mm 1.50		BLACK	
	WA8650/170-6550E14	8x6.50"/8x170mm	6x5.50"	2"	126.15mm	-	14mm 1.50	X		YES
	WA8650-6550E	8x6.50"	6x5.50"	2"	126.15mm	-	14mm 1.50			YES
	WA8650-8170C14	8x6.50"	8x170mm	1.5"	126.15mm	-	14mm 1.50			
	WA8650-8170C916	8x6.50"	8x170mm	1.5"	126.15mm	-	9/16"-18			
	WA8650-8170E14	8x6.50"	8x170mm	2"	126.15mm	-	14mm 1.50			
	WA8650-8180C14	8x6.50"	8x180mm	1.5"	126.15mm	-	14mm 1.50			
	WA8650-8180E14	8x6.50"	8x180mm	2"	126.15mm	-	14mm 1.50			
	WA8650-8180EH14	8x6.50"	8x180mm	2"	124mm	124mm	14mm 1.50			
	WA8650-8210E14	8x6.50"	8x210mm	2"	116.7mm	-	14mm 1.50			
	WA8650-8650C	8x6.50"	8x6.50"	1.5"	126.15mm	-	9/16"-18			
	WA8650-8650C14	8x6.50"	8x6.50"	1.5"	126.15mm	-	14mm 1.50			
	WA8650-8650E	8x6.50"	8x6.50"	2"	126.15mm	-	9/16"-18			
	WA8650-8650E14	8x6.50"	8x6.50"	2"	126.15mm	-	14mm 1.50			
	WA8650-8650EBK	8x6.50"	8x6.50"	2"	126.15mm	-	9/16"-18		BLACK	
	WA8650-8650EH14	8x6.50"	8x6.50"	2"	116.7mm	116.7mm	14mm 1.50			